

# **Instrument Messages and Functional Tests**

## **Agilent Technologies ESA Series Spectrum Analyzers**

**This manual documents firmware revision A.08.xx**

**This manual provides documentation for the following instruments:**

### **Agilent Technologies ESA-E Series**

**E4401B (9 kHz- 1.5 GHz)  
E4402B (9 kHz - 3.0 GHz)  
E4404B (9 kHz - 6.7 GHz)  
E4405B (9 kHz - 13.2 GHz)  
E4407B (9 kHz - 26.5 GHz)**

**and**

### **Agilent Technologies ESA-L Series**

**E4411B (9 kHz- 1.5 GHz)  
E4403B (9 kHz - 3.0 GHz)  
E4408B (9 kHz - 26.5 GHz)**



**Manufacturing Part Number: E4401-90410**

**Printed in USA  
December 2001**

© Copyright 2001 Agilent Technologies

---

## **Notice**

The information contained in this document is subject to change without notice.

Agilent Technologies makes no warranty of any kind with regard to this material, including but not limited to, the implied warranties of merchantability and fitness for a particular purpose. Agilent Technologies shall not be liable for errors contained herein or for incidental or consequential damages in connection with the furnishing, performance, or use of this material.

---

## **Where to Find the Latest Information**

Documentation is updated periodically. For the latest information about Agilent Technologies **ESA** Spectrum Analyzers, including firmware upgrades and application information, please visit the following Internet URL:

<http://www.agilent.com/find/esa>

Microsoft® is a U.S. registered trademark of Microsoft Corp.

---

# Contents

## 1. Instrument Messages

Instrument Messages Introduction .....	16
Error Message Format .....	17
Error Message Types .....	18
Instrument Messages .....	20
Error Messages .....	20
Instrument Messages without Numbers .....	58

## 2. Functional Testing

What You Will Find in This Chapter .....	74
What Are the Functional Tests? .....	74
Functional Test Versus Performance Verification .....	74
Test Descriptions .....	75
Displayed Average Noise Level .....	78
Test Limits .....	78
Test Description .....	79
Required Equipment .....	79
Procedure (10 MHz to 500 MHz) E4401B and E4411B .....	80
Procedure (501 MHz to 1.0 GHz) E4401B and E4411B .....	81
Procedure (1.01 GHz to 1.5 GHz) E4401B and E4411B .....	82
Procedure (10 MHz to 1 GHz) E4402B, E4403B, E4404B, E4405B, E4407B, and E4408B .....	83
Procedure (1.01 GHz to 2 GHz) E4402B, E4403B, E4404B, E4405B, E4407B, and E4408B .....	85
Procedure (2.01 GHz to 3.0 GHz) E4402B, E4403B, E4404B, E4405B, E4407B, and E4408B .....	86
Procedure (3.01 GHz to 6.0 GHz) E4404B, E4405B, E4407B, and E4408B .....	87
Procedure (6.01 GHz to 6.7 GHz) E4404B .....	88
Procedure (6.01 GHz to 12.0 GHz) E4405B, E4407B, and E4408B .....	90
Procedure (12.01 GHz to 13.2 GHz) E4405B .....	91
Procedure (12.01 GHz to 22 GHz) E4407B and E4408B .....	92
Procedure (22.01 GHz to 26.5 GHz) E4407B and E4408B .....	93
Frequency Readout Accuracy .....	96
Test Limits .....	96
Test Description .....	96
Required Equipment .....	96
Procedure .....	97
Marker Count Accuracy .....	99
Procedure .....	99
Frequency Response .....	100
Test Limits .....	100
Test Description .....	100

---

# Contents

Required Equipment .....	100
Procedure .....	102
Reference Level Accuracy .....	105
Test Limits .....	105
Test Description .....	105
Required Equipment .....	105
Log Mode Procedure .....	106
Linear Mode Procedure .....	108
Resolution Bandwidth Switching Uncertainty .....	110
Test Limits .....	110
Test Description .....	110
Required Equipment .....	110
Procedure .....	111
Scale Fidelity .....	113
Test Limits .....	113
Test Description .....	113
Required Equipment .....	113
Procedure .....	114
Second Harmonic Spurious Responses .....	116
Test Limits .....	116
Test Description .....	116
Required Equipment .....	116
Procedure .....	117
Tracking Generator Level Flatness: Models E4401B and E4411B, Options 1DN and 1DQ .....	119
Test Limits .....	119
Test Description .....	119
Required Equipment .....	119
Procedure .....	120
Tracking Generator Level Flatness: E4402B, E4403B, E4404B, E4405B, E4407B and E4408B, Option 1DN .....	122
Test Limits .....	122
Test Description .....	122
Required Equipment .....	122
Procedure .....	123

---

**Instrument Messages**  
**Alphabetical Listing**

(50 MHz Osc Unleveled) .....	58
(Freq Ref Unlocked) .....	60
(IF/ADC Over Range) .....	61
(LO Out Unleveled) .....	61
(no corresponding status bit) .....	60
(Oversweep) .....	62
(Source LO Unleveled) .....	63
(Source Unleveled) .....	63
(Synth Unlocked) .....	62
(ADC Align Failure) .....	58
(FM Demod Align Failure) status bit only, no message .....	60
(IF Align Failure) status bit only, no message .....	60
(LO Align Failure) status bit only, no message .....	61
(RF Align Failure) status bit only, no message .....	63
(TG Align Failure) status bit only, no message .....	64
* (Invalid Data) .....	58
: Reduce Signal and press <ESC> (Input Overload Tripped) .....	62
<directoryname> directory deleted .....	65
<directoryname1> directory renamed to <directoryname2> .....	66
<filename> file copied .....	66
<filename> file deleted .....	66
<filename> file loaded .....	66
<filename> file saved .....	66
<filename> too many data entries .....	67
<filename1> file renamed to <filename2> .....	66
'10101010' pattern not detected - results may be inaccurate. ....	49
100 spurs found. Additional spurs ignored. ....	55
10537 Cancellation trace has different X-Scale to Smoothed trace. ....	57
50 MHz Osc Unlevel .....	58
Align Now All Needed (Align Needed) .....	58
Align Now RF Needed (Align Now RF Needed) .....	59
Align RF Skipped (Align RF Skipped) .....	59
Align .....	70
Atten auto set to 15 dB .....	64

---

## **Instrument Messages**

### **Alphabetical Listing**

Auto Align not available when using Calibration Defaults.....	32
Auto ranging.....	64
Average Type incompatible for scale. ....	29
AVG 3 .....	94
Avg Mode changed to Exp for Examine Meas Type. ....	54
Avg Mode changed to Repeat for Full Meas Type. ....	54
Awaiting trigger .....	43
B7D and/or B7E not found. Code Domain not available.....	64
B7D and/or B7E not found. Mod Acc not available.....	64
B7D DSP Code Install Fail Opt.229.Contact your Service Center.....	52
B7D DSP Code Install Fail Opt.231.Contact your Service Center.....	53
B7D DSP Code Reload Fail Opt.229.Contact your Service Center. ....	52
B7D DSP Code Reload Fail. Opt.231.Contact your Service Center.....	54
Bad or missing floppy disk .....	31
Band Measurement not defined for Out of Band. ....	41
Block data error .....	23
Block data not allowed. ....	22
Burst not found. ....	47
Cal Data corrupt. Wideband cal failed. Using previous data.....	51
Can't Auto-Couple RBW in Zero Span .....	31
Can't Auto-Couple Sweep Time in Zero Span. ....	31
Can't compute result - not enough transitions. ....	50
Cancellation disabled while measuring DANL Floor. ....	57
Cancellation trace is not set to Reference or has no data.....	57
Cannot correlate to input signal .....	44
Cannot display Trace because it contains no data. ....	55
Cannot find the Power vs Time Limits File.....	41
Cannot load a directory, please choose a file .....	37
Cannot lock to carrier. ....	53
Cannot open trace file for writing. Save Failed.....	56
Cannot save Trace because it contains no data.....	56
Cannot update the list of cable types on drive C:.....	42
Cannot update the list of cable types.....	42
Carrier Not Present. Verify frequency and amplitude settings. ....	57

---

**Instrument Messages**  
**Alphabetical Listing**

Carrier Not Present . . . . .	53
Carrier Not Present . . . . .	65
Carrier Present. Test Stopped!. . . . .	42
Channel frequency outside device's transmit band. . . . .	65
Character data error. . . . .	24
Character data not allowed . . . . .	23
Character data too long . . . . .	23
Command error. . . . .	27
Command header error . . . . .	26
Command not recognized . . . . .	27
Command not valid in this model . . . . .	29
Command not valid when no measurement is active . . . . .	29
Connect Amptd Ref Output to Input . . . . .	32
Connect RF OUT to INPUT . . . . .	31
Corrupted file . . . . .	31
Data corrupt or stale. . . . .	21
Data type error . . . . .	26
DC Coupled . . . . .	59
Default spur table values loaded. . . . .	65
Demod Format setting does not allow this value for Points/Symbol. . . . .	52
Demod ON: reduce span for audible detection . . . . .	60
Device = Mobile. Code Domain not available. . . . .	65
Device = Mobile. Mod Acc not available. . . . .	65
Device-specific error . . . . .	21
Directory already exists . . . . .	66
DSP algorithm timeout, aborting measurement. . . . .	40
DSP timed out, resetting DSP. . . . .	44
Emission bandwidth not found. Consider increasing span. . . . .	47
Entire trace is below the threshold level. . . . .	66
Entire trace is below threshold level . . . . .	41
Error reading file: CDMASTUN.CSV. Please reinstall cdmaOne. . . . .	45
Error reading file: CDPMDA. Please reinstall cdmaOne. . . . .	46
Error reading file: CDPPMCO. Please reinstall cdmaOne. . . . .	46
Error reading file: CDPPMDA. Please reinstall cdmaOne. . . . .	46

---

## Instrument Messages

### Alphabetical Listing

Error reading file: OOBSTAB.CSV. Use Edit Table   Save Table.....	46
Error reading file: RHODMDA. Please reinstall cdmaOne. ....	46
Error reading file: RHOPMCO. Please reinstall cdmaOne. ....	46
Error reading file: SPCLIMIT.CSV. Cannot use custom limits. ....	45
Execution error. ....	22
Exponent too large. ....	25
Exponent too large. ....	25
Expression data error. ....	22
Expression data not allowed. ....	22
Ext Ref. ....	60
Ext Ref. ....	70
Failed to Load trace. Bad file format. ....	56
File access is denied. ....	30
File already exists. ....	30
File Name Error. ....	30
File not found. ....	30
Flash memory is full. ....	31
Flat corr off (no corresponding status bit). ....	60
Floppy disk error. ....	30
Floppy disk full. ....	29
Freq corr off (no corresponding status bit). ....	60
FreqRefUnlock. ....	70
Frequency Reference Error. ....	60
Gate option not installed. Results may not be accurate. ....	42
GET not allowed. ....	26
Hardkeys are disabled. ....	43
Header separator error. ....	25
Header suffix out of range. ....	25
IF Gain fixed. ....	61
IF Overload. ....	61
Illegal write access of Flash memory. ....	31
In <command>; bad data count (<numeric_value>): expected multiple of <numeric_value>. ....	33
In <filename>, line <nnn>; separator missing. ....	33
In <filename>, line <numeric_value>; <xxx> is not numeric. ....	34



---

**Instrument Messages**  
**Alphabetical Listing**

In <filename>, line <numeric_value>: error parsing tokens .....	34
In <filename>, line <numeric_value>: line too long .....	33
In <filename>: [DATA] header missing .....	33
In <filename>: bad amplitude unit <unit> .....	34
In <filename>: error reading file .....	33
Incorrect filename, allowable extensions are .gif or .wmf .....	36
Incorrect filename, allowable extensions are .trc or .csv .....	36
Input is internal (no corresponding status bit) .....	61
Instrument mode requested is not supported .....	36
Instrument state may be corrupt, state has been reset to initial values .....	35
Interpolation error: cannot compute log of <negative_frequency_value> .....	34
Invalid Baud Rate .....	28
Invalid block data .....	23
Invalid character data .....	24
Invalid character in number .....	25
Invalid character .....	27
Invalid expression .....	22
Invalid format: CSV files are not supported by this measurement .....	67
Invalid instrument mode .....	36
Invalid Marker Trace .....	56
Invalid option, unable to uninstall package .....	29
Invalid printer response .....	32
Invalid separator .....	26
Invalid string data .....	23
Invalid suffix .....	24
Level is low, results may degrade .....	44
LO Out Unlevel .....	61
LO Unlevel (LO Unleveled) .....	61
LO Unlock .....	62
Log Corr Off (no corresponding status bit) .....	62
Lost trigger, aborting measurement .....	40
Lower Custom Mask is Invalid! .....	41
Marker Count:Widen Res BW .....	62
Meas Type changed to Examine for Exp Avg Mode .....	54

---

## Instrument Messages

### Alphabetical Listing

Meas Type changed to Full for Repeat Avg Mode. . . . .	55
Meas Uncal. . . . .	62
Measurement does not support the current radio standard. . . . .	43
Measurement failed for unknown reasons. . . . .	44
Measurement halted. Press a measurement key to continue. . . . .	67
Measurement not defined for Out of Band. . . . .	40
Measurement suspended until carrier is turned off. . . . .	43
Measurement uncalibrated, symbol rate exceeds +/-10% nominal. . . . .	51
Measurement uncalibrated, wideband calibration required. . . . .	51
Media is corrupt. . . . .	30
Media is not writable . . . . .	30
Media is protected . . . . .	30
Missing parameter . . . . .	26
No error . . . . .	20
No Fast ADC hardware installed. Meas unavailable. . . . .	40
No Fast ADC hardware installed. Meas unavailable. . . . .	67
No Fast ADC hardware installed. . . . .	40
No Fundamental > 0 Hz found in given span. . . . .	37
No Fundamental > -50 dBm found in given span. . . . .	37
No peak found . . . . .	27
No ranges are defined. . . . .	55
No spurs have been found. . . . .	55
Not enough frequency range to measure harmonics for channel. . . . .	67
Numeric data error . . . . .	25
Numeric data not allowed . . . . .	24
One or more harmonics beyond freq limit: number decreased. . . . .	37
One or more harmonics beyond freq limit: number decreased. . . . .	67
Opt 106 demod hardware required. Meas unavailable. . . . .	48
Opt 106 hardware required. Preamble sync unavailable. . . . .	48
Opt 229 DSP algorithm code file requires upgrade. . . . .	52
Opt 229 DSP algorithm coef. file requires upgrade. . . . .	52
Opt 231 DSP algorithm code file requires upgrade. . . . .	54
Opt 231 DSP algorithm coef. file requires upgrade. . . . .	54
Opt AXX hardware required. Meas unavailable. . . . .	39

---

**Instrument Messages**  
**Alphabetical Listing**

Opt B7D & B7E hardware required. Meas unavailable. ....	39
Opt B7D bootrom requires upgrade. ....	39
Opt B7D or AYX FADC hardware required. Meas unavailable. ....	48
Opt B7E RF hardware required. RF Burst unavailable. ....	48
Opt BAH DSP algorithm code file requires upgrade. ....	39
Opt BAH DSP algorithm coef. file requires upgrade. ....	40
Opt BAH DSP algorithm files failed to load, aborting measure. ....	40
Opt BAH DSP algorithm files not installed. Meas unavailable. ....	39
Opt Freq Ref setting does not match external reference. ....	45
Option activated . ....	67
Option not installed . ....	27
Option not licensed. ....	29
Overload . ....	62
Overload . ....	70
Parameter not allowed . ....	26
Parameter unavailable in demod measurements. ....	48
Payload data pattern '10101010' not present. ....	49
Peaking Signal (no corresponding status bit) . ....	62
Please set RF input range (INPUT menu) to manual first. ....	68
Preferred resolution bandwidth not available. ....	62
Preselector centering failed . ....	28
Printer interface error . ....	33
Printer Type is None. ....	33
Program mnemonic too long. ....	25
Query DEADLOCKED . ....	20
Query Error. ....	21
Query INTERRUPTED . ....	20
Query UNTERMINATED after indefinite response. ....	20
Query UNTERMINATED. ....	20
Radio standard is not supported by the current measurement. ....	43
RBW limited to 1 kHz when Span > 5 MHz . ....	28
Required payload data pattern '10101010' not present. ....	49
Required payload data pattern '11110000' not present. ....	49
Resolution BW <300 kHz. ....	41

---

## Instrument Messages

### Alphabetical Listing

RF Board could not detect any bursts in signal. . . . .	45
RF Board LO Unlocked. Contact service center. . . . .	44
RF Board RF Osc Unlocked. Contact service center. . . . .	45
RF Board SR Osc Unlocked. Contact service center. . . . .	45
RF Signal not found. . . . .	44
RS-232 Interface Error . . . . .	29
Second harmonic is beyond analyzer frequency limit. . . . .	37
Settings conflict; parameter currently disabled. . . . .	22
Shutdown in process. . . . .	68
Signal Ident On, Amptd Uncal (Signal Ident On) . . . . .	63
Signal level is low. . . . .	63
Signal Tracking disabled when measuring DANL Floor (Removal). . . . .	57
Source LO Unlevel . . . . .	63
Source LO Unlock (Source Synth Unlocked) . . . . .	63
Source Unlevel . . . . .	63
Span limited to 5 MHz when RBW < 1 kHz. . . . .	28
Start Marker must be at least 1% < Stop Marker. . . . .	48
Stop Marker must be at least 1% > Start Marker. . . . .	48
Store Ref trace before turning on Normalize . . . . .	37
String data error . . . . .	23
String data not allowed . . . . .	23
Suffix error . . . . .	24
Suffix not allowed. . . . .	24
Suffix too long. . . . .	24
Sweep Time too fast (<2 sec) . . . . .	42
Sync word not found in frame (Burst Type) . . . . .	38
Sync word not found in frame (Ref Burst) . . . . .	38
Sync word not found in frame (TSC). . . . .	50
Sync word not found in specified timeslot (Burst Type) . . . . .	38
Sync word not found in specified timeslot (TSC).. . . . .	51
Syntax error . . . . .	26
System Alignments, Align Now, All Required . . . . .	63
System error. . . . .	21
Table could not be loaded. . . . .	47

---

**Instrument Messages**  
**Alphabetical Listing**

Table could not be saved. . . . .	46
Table loaded successfully. . . . .	68
Table saved successfully. . . . .	68
TG Frequency Limit . . . . .	27
TG start freq is less than 1/2 res bw . . . . .	28
TG start freq is less than 9 kHz. . . . .	28
The Cable Fault Measurement is active. Mode Setup is disabled. . . . .	42
The calibration data is invalid, and has been cleared. . . . .	68
The file containing the list of cable types has been updated. . . . .	68
The regression portion failed. . . . .	44
There are no spurs to inspect. . . . .	42
There is no valid result to hold. . . . .	49
This measurement does not support the *.CSV file format. . . . .	55
This measurement does not support the *.CSV file format. . . . .	69
This operation requires a measurement to be active. . . . .	52
This operation requires a measurement to be active. . . . .	69
Too many data values at <freq_or_time_value> . . . . .	34
Too many digits. . . . .	25
Too much data; <description of the type of data exceeded> . . . . .	21
Trace file contains no compatible traces. . . . .	56
Trace file saved successfully. . . . .	57
Trace file was created by incompatible version of Opt. 226 . . . . .	56
Tracking Generator hardware is not present. Meas unavailable. . . . .	41
Tracking Peak Needed. . . . .	69
Trigger Offset unavailable in swept spans . . . . .	29
Unable to Calculate Result using Current Setup. . . . .	49
Unable to initialize flatness data. . . . .	28
Unable to load file. . . . .	36
Unable to load state from file. . . . .	35
Unable to load state from register . . . . .	35
Unable to load state . . . . .	35
Unable to load user state, factory preset was done . . . . .	35
Unable to query state . . . . .	35
Unable to save file . . . . .	36

---

## Instrument Messages

### Alphabetical Listing

Unable to save state to file .....	35
Unable to save state to register.....	35
Unable to save user state .....	35
Unable to set state .....	36
Unable to store flatness data.....	28
Unable to uninstall personality, file not deletable.....	58
Uncal.....	71
Undefined header.....	25
Unknown demod status.....	39
Unknown printer .....	32
Unlevel .....	71
Unlock.....	71
Unsupported printer .....	32
Upper Custom Mask is Invalid! .....	41
Use View/Trace menu when loading or saving logarithmic traces.....	55
Valid Bluetooth burst not found.(Check Packet Type).....	47
Valid burst not found in frame (Burst Type).....	50
Valid burst not found in specified timeslot (Burst Type).....	50
Valid burst not found.....	53
Valid GSM burst not found in frame (Burst Type).....	38
Valid GSM burst not found in frame (Ref Burst).....	38
Valid GSM burst not found in specified timeslot (Burst Type).....	38
Valid signal not found.....	50
Video shift off (no corresponding status bit).....	64
Volume <name> formatted .....	69
WARNING: You are about to delete all of the contents on directory "x:\xxxxx\". Press Delete Now again to proceed or any other key to abort.....	69
Wideband calibration not valid until Align Now, All performed.....	51
Wrong density floppy inserted.....	31

---

# **1 Instrument Messages**

## Instrument Messages Introduction

The analyzer can generate various messages that appear on the display during operation. There are four types of messages.

- **Status Messages**, beginning on [page 58](#), appear on the right side of the analyzer display and/or set status bits in the SCPI Status Register system. These messages indicate a condition that may result in erroneous data being displayed. Most messages will only be displayed until the error condition is corrected. Multiple messages can be displayed and will be listed in the display area. In each case the name of the corresponding status bit is indicated in parenthesis. It will be noted if only a status bit is used (no message).
- **Informational Messages**, beginning on [page 64](#), provide information that requires intervention. These messages appear in the status line at the bottom of the display. If you have a color display and are using the default display colors, the message will appear in green. The message will remain until you preset the analyzer, press **ESC**, or another message is displayed in the status line. The information provided in brackets, for example <filename> or <directory>, is a variable that represents a specific input provided previously.
- **Annunciator Bar Messages**, beginning on [page 70](#), provide Status Message information and appear on the left or right side of the annunciator bar of the analyzer display when running measurements. Some of the messages appear on the left side of the annunciator bar in red and other appear on the right side of the annunciator bar in green. An annunciator bar message may map to several different status messages, and you should check the related status messages to determine the cause of your annunciator message. For more information on status messages, refer to [Status Messages](#) above.
- User **Error Messages**, beginning on [page 20](#), appear when an attempt has been made to set a parameter incorrectly or an operation has failed (such as saving a file). These messages are often generated during remote operation when an invalid programming command has been entered. These messages appear in the status line at the bottom of the display. If you have a color display and are using the default display colors, the message will appear in yellow. The message will remain until you preset the analyzer, press **ESC**, or another message is displayed in the status line. A summary of the last 30 error messages preceded by an error number may be viewed in the Error Queue by pressing, **System** then **Show Errors**. Refer to [Table 1-1](#) for more information on the characteristics of the Error Queue. When a remote interface initiates activity that generates an error, the messages are output to the remote bus. When output to the remote interface, they are preceded by an error number.



When a user error condition occurs in the analyzer as a result of SCPI (remote interface) activity, it is reported to both the front panel display error queue and the SCPI error queue. If it is a result of front panel activity, it reports to the front panel display error queue, and depending on the error, may also report to the SCPI error queue. These two queues are viewed and managed separately.

**Table 1-1 Characteristics of the Error Queue**

Characteristic	Front Panel Display Error Queue	SCPI Remote Interface Error Queue
Capacity (number of errors)	30	30
Overflow Handling	Circular (rotating). Drops oldest error as new error comes in.	Linear, first-in/first-out. Replaces newest error with: -350, Queue overflow
Viewing Entries	Press: <b>System, Show Errors</b>	Use SCPI query SYSTem:ERRor?
Clearing the Queue	Press: <b>System, Show Errors, Clear Error Queue</b>	Power up. Send a *CLS command. Read last item in the queue.

Note that the error number is displayed under the **System, Show Errors** key sequence.

- Pop-up Messages indicate a condition that may require intervention. They appear in the middle of the display in a framed box. The message will remain until the appropriate intervention has taken place or the condition has been corrected.

### Error Message Format

The system-defined error numbers are chosen on an enumerated (“1 of N”) basis. The error messages are listed in numerical order according to the error message number. Status and Informational messages without numbers will be listed in alphabetical order following the numerical listing.

---

**NOTE**

To see an error *number*, view the error queue as described on [page 17](#).

In this chapter, an explanation is included with each error to further clarify its meaning. The last error described in each class (for example, -400, -300, -200, -100) is a “generic” error. There are also references to the IEEE Standard 488.2-1992, *IEEE Standard Codes, Formats, Protocols and Common Commands for Use with ANSI/IEEE Std 488.1-1987*. New York, NY, 1992.

Error messages are displayed at the bottom of the screen in the status line (yellow on color displays). The error number is available through the remote interface and the show errors screen; it is not displayed in the status line.

**Figure 1-1 Error Message Example**

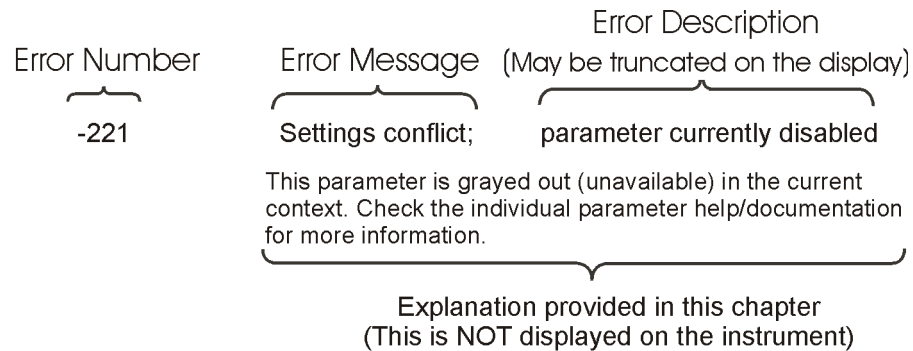

pk716b

## Error Message Types

Events do not generate more than one type of error. For example, an event that generates a query error will not generate a device-specific, execution, or command error.

### -499 to -400: Query Errors

These errors indicate that the analyzer output queue control has detected a problem with the message exchange protocol described in IEEE 488.2, Chapter 6. Errors in this class set the query error bit (bit 2) in the event status register (IEEE 488.2, section 11.5.1). These errors correspond to message exchange protocol errors described in IEEE 488.2, 6.5. In this case:

- Either an attempt is being made to read data from the output queue when no output is either present or pending, or
- data in the output queue has been lost.

### -399 to -300: Device-Specific Errors

An error number in the range -399 to -300 indicates that the analyzer has detected an error where some device operations did not properly complete, possibly due to an abnormal hardware or firmware condition. This is not a error in response to a SCPI query or command, or command execution. The occurrence of any error in this class will cause the device-specific error bit (bit 3) in the event status register to be set.

### -299 to -200: Execution Errors

These errors indicate that an error has been detected during analyzer execution.

**-199 to -100:  
Command Errors** These errors indicate that the analyzer parser detected an IEEE 488.2 syntax error. Errors in this class set the command error bit (bit 5) in the event status register (IEEE 488.2, section 11.5.1). In this case:

- Either an IEEE 488.2 syntax error has been detected by the parser (a control-to-device message was received that is in violation of the IEEE 488.2 standard. Possible violations include a data element which violates device listening formats or whose type is unacceptable to the device.), or
- an unrecognized header was received. These include incorrect device-specific headers and incorrect or unimplemented IEEE 488.2 common commands.

**201 to 799:  
Device-Specific  
Errors** These errors indicate that a device operation did not properly complete, possibly due to an abnormal hardware or firmware condition. These codes are also used for self-test response errors. Errors in this class set the device-specific error bit (bit 3) in the event status register (IEEE 488.2, section 11.5.1).

The <error\_message> string for a positive error is not part of the SCPI standard. A positive error indicates that the analyzer detected an error within the GPIB system, within the analyzer firmware or hardware, during the transfer of block data, or during calibration.

**Greater than  
10000:  
Measurement  
Applications  
Errors** These errors indicate that an error has been detected while executing measurements requiring a personality option such as Option BAH, the GSM Measurement Personality or those measurements found under the **MEASURE** front-panel key in Spectrum Analyzer mode.

---

## Instrument Messages

### Error Messages

---

**NOTE** Error numbers are displayed in the error queue, *not* on the display.  
To see an error *number*, view the error queue as described on [page 17](#).

---

**0** No error

The queue is empty. Every error in the queue has been read or the queue was purposely cleared by power-on or \*CLS.

#### **-499 to -400: Query Errors**

---

**NOTE** Error numbers are displayed in the error queue, *not* on the display.  
To see an error *number*, view the error queue as described on [page 17](#).

---

**-440** Query UNTERMINATED after indefinite response

Indicates that a query was received in the same program message after a query requesting an indefinite response was executed (see IEEE 488.2, 6.3.7.5).

**-430** Query DEADLOCKED

Indicates that a condition causing a DEADLOCKED query error occurred (see IEEE 488.2, 6.3.1.7). For example, both the input buffer and the output buffer are full and the analyzer cannot continue. The analyzer automatically discards output to correct the deadlock.

**-420** Query UNTERMINATED

Indicates that a condition causing an UNTERMINATED query error occurred (see IEEE 488.2, 6.3.2.2). For example, the device was addressed to talk and an incomplete program message was received.

**-410** Query INTERRUPTED

Indicates that a condition causing an INTERRUPTED query error occurred (see IEEE 488.2, 6.3.2.7). For example, a query was followed by DAB or GET before a response was completely sent.

-400 Query Error

This is a generic query error for devices that cannot detect more specific errors. The code indicates only that a query error as defined in IEEE 488.2, 11.5.1.1.7, and 6.3 has occurred.

**-399 to -300: Device-Specific Errors**

---

NOTE

Error numbers are displayed in the error queue, *not* on the display.

To see an error *number*, view the error queue as described on [page 17](#).

---

-310 System error

Indicates that an error, termed “system error” by the device, has occurred.

-300 Device-specific error

This is a generic device-dependent error for devices that cannot detect more specific errors. The code indicates only that a device-dependent error as defined in IEEE 488.2, 11.5.1.1.6 has occurred.

**-299 to -200: Execution Errors**

---

NOTE

Error numbers are displayed in the error queue, *not* on the display.

To see an error *number*, view the error queue as described on [page 17](#).

---

-230 Data corrupt or stale.

Possibly invalid data. A new measurement was started but not completed.

-223 Too much data; <description of the type of data exceeded>

Indicates that a legal program data element of block, expression or string type was received that contained more data than the device could handle due to memory or related device-specific requirements.

- 221            Settings conflict; parameter currently disabled
- This parameter is grayed out (unavailable) in the current context. Check the individual parameter help/documentation for more information.
- 200            Execution error
- This is a generic execution error for devices that cannot detect more specific errors. The code indicates only that a execution error as defined in IEEE 488.2, 11.5.1.1.4 has occurred.

### **-199 to -100: Command Errors**

---

**NOTE**            Error numbers are displayed in the error queue, *not* on the display.  
To see an error *number*, view the error queue as described on [page 17](#).

---

- 178            Expression data not allowed
- A legal expression data was encountered, but was not allowed by the device at this point in parsing.
- 171            Invalid expression
- The expression data element was invalid (see IEEE 488.2, 7.7.7.2). For example, unmatched parentheses or an illegal character.
- 170            Expression data error
- This error, as well as errors -171 through -179, is generated when parsing an expression data element. This particular error message is used if the device cannot detect a more specific error.
- 168            Block data not allowed
- A legal block data element was encountered, but not allowed by the device at this point in the parsing.

- 161** Invalid block data  
A block data element was expected, but was invalid (see IEEE 488.2, 7.7.6.2). For example, an END message was received before the end length was satisfied.
- 160** Block data error  
This error, as well as errors –161 through –169, is generated when parsing a block data element. This particular error message is used if the device cannot detect a more specific error.
- 158** String data not allowed  
A string data element was encountered, but not allowed by the device at this point in the parsing.
- 151** Invalid string data  
A string data element was expected, but was invalid (see IEEE 488.2, 7.7.5.2). For example, an END message was received before the terminal quote character.
- 150** String data error  
This error, as well as errors –151 through –159, is generated when parsing a string data element. This particular error message is used if the device cannot detect a more specific error.
- 148** Character data not allowed  
A legal character data element was encountered where prohibited by the device.
- 144** Character data too long  
The character data element contains more than twelve characters (see IEEE 488.2, 7.7.1.4).

- 141 Invalid character data  
Either the character data element contains an invalid character or the particular element received is not valid for the header.
- 140 Character data error  
This error, as well as errors -141 through -149, is generated when parsing a character data element. This particular error message is used if the device cannot detect a more specific error.
- 138 Suffix not allowed  
A suffix was encountered after a numeric element which does not allow suffixes.
- 134 Suffix too long  
The suffix contained more than twelve characters (see IEEE 488.2, 7.7.3.4).
- 131 Invalid suffix  
The suffix does not follow the syntax described in IEEE 488.2, 7.7.3.2, or the suffix is inappropriate for this device.
- 130 Suffix error  
This error, as well as errors -131 through -139, is generated when parsing a suffix. This particular error message is used if the device cannot detect a more specific error.
- 128 Numeric data not allowed  
A legal numeric data element was received, but the device does not accept one in this position for the header.



- 124**      Too many digits  
The mantissa of a decimal-numeric data element contained more than 255 digits excluding leading zeros (see IEEE 488.2, 7.7.2.4.1).
- 123**      Exponent too large  
The magnitude of an exponent was greater than 32000 (see IEEE 488.2, 7.7.2.4.1).
- 121**      Invalid character in number  
An invalid character for the data type being parsed was encountered. For example, an alpha in a decimal numeric or a “9” in octal data.
- 120**      Numeric data error  
This error, as well as errors –121 through –129, is generated when parsing a data element which appears to be numeric, including non-decimal numeric types. This particular error message is used if the device cannot detect a more specific error.
- 114**      Header suffix out of range  
The value of a header suffix attached to a program mnemonic makes the header invalid.
- 113**      Undefined header  
The header is syntactically correct, but it is undefined for this specific device. For example, \*XYZ is not defined for any device.
- 112**      Program mnemonic too long  
The header contains more than twelve characters (see IEEE 488.2, 7.6.1.4.1).
- 111**      Header separator error  
A character which is not a legal header separator was encountered while parsing the header.

- 110**            Command header error
- An error was detected in the header. This message is used when the device cannot detect the more specific errors described for errors -111 through -119.
- 109**            Missing parameter
- Fewer parameters were received than required for the header. For example, the \*ESE common command requires one parameter, so receiving \*ESE is not allowed.
- 108**            Parameter not allowed
- More parameters were received than expected for the header. For example, the \*ESE common command only accepts one parameter, so receiving \*ESE 0,1 is not allowed.
- 105**            GET not allowed
- A Group Execute Trigger was received within a program message (see IEEE 488.2, 7.7). Correct the GPIB controller program so that the GET does not occur within a line of GPIB program code.
- 104**            Data type error
- The parser recognized a data element that is not allowed. For example, numeric or string data was expected, but block data was encountered.
- 103**            Invalid separator
- The parser was expecting a separator and encountered an illegal character. For example, the semicolon was omitted after a program message unit.
- 102**            Syntax error
- An unrecognized command or data type was encountered. For example, a string was received when the device does not accept strings.

-101 Invalid character

A syntactic command contains a character which is invalid for that type. For example, a header containing an ampersand, such as "SETUP&". This error might be used in place of error numbers -114, -121, -141, and some others.

-100 Command error

This is a generic syntax error for devices that cannot detect more specific errors. The code indicates only that a command error as defined in IEEE 488.2, 11.5.1.1.4 has occurred.

### 201 to 799: Device-Specific Errors

---

NOTE Error numbers are displayed in the error queue, *not* on the display.  
To see an error *number*, view the error queue as described on [page 17](#).

---

201 Option not installed

The desired operation cannot be performed because a required option is not installed. For example, pressing **Source** with no tracking generator installed in the analyzer will generate this error.

202 No peak found

No signal peak was found.

204 TG Frequency Limit

The tracking generator has reached the limit of its allowable frequency range.

205 Command not recognized

Indicates that the command sent from the remote interface was not recognized. Check the programming guide for correct syntax.

- 206            Unable to initialize flatness data  
**A failure occurred in setting the flatness data in the internal EEROM. Get in touch with your local Agilent Technologies sales and service office.**
- 207            Unable to store flatness data  
**A failure occurred in setting the flatness data in the internal EEROM. Get in touch with your local Agilent Technologies sales and service office.**
- 209            Preselector centering failed  
**An attempt to center the preselector failed.**
- 211            RBW limited to 1 kHz when Span > 5 MHz  
**In spans greater than 5 MHz, narrow (digital) resolution bandwidths, below 1 kHz, are not available.**
- 213            Span limited to 5 MHz when RBW < 1 kHz  
**In narrow (digital) resolution bandwidths, below 1 kHz, spans greater than 5 MHz are not available.**
- 214            TG start freq is less than 9 kHz  
**Tracking generator uncalibrated below 9 kHz.**
- 215            TG start freq is less than 1/2 res bw  
**Tracking generator uncalibrated at start frequencies below 1/2 the current resolution bandwidth.**
- 216            Invalid Baud Rate  
**Attempt to use invalid baud rate. Refer to the programming language chapter of *Agilent Technologies ESA Series Spectrum Analyzer Programmer's Guide* for more information.**

- 217 RS-232 Interface Error  
**An error occurred on the serial interface.**
- 219 Command not valid in this model  
**Indicates that the command sent from the remote interface does not apply to this model number. For example, attempting to center the preselector in an analyzer without a preselector will generate this error.**
- 221 Invalid option, unable to uninstall package  
**You have attempted to remove a personality that is not currently installed. Verify command was entered correctly.**
- 222 Command not valid when no measurement is active  
**Indicates that the command sent from the remote interface must be issued while a measurement is running in the analyzer.**
- 223 Trigger Offset unavailable in swept spans  
**Trigger Offset is only available in Zero Span. Refer to “Trig” in the Agilent ESA Spectrum Analyzer User’s Guide for a description of this function.**
- 224 Option not licensed.  
**The selected option requires a license. Refer to the installation procedures in the user’s guide available for this particular option.**
- 332 Average Type incompatible for scale.  
**Amplitude Scale command should be sent prior to the Average Type command.**
- 601 Floppy disk full  
**The floppy disk is full. Clear some space by deleting unwanted files.**

- 602 Floppy disk error  
An unknown error has occurred while accessing the floppy disk.
- 604 File already exists  
Attempt to save to a file that already exists. Delete or rename the old file and try again.
- 605 Media is protected  
A save was attempted to a write-protected device.
- 606 Media is corrupt  
A save was attempted to a corrupt device.
- 607 File Name Error  
An invalid file name has been specified. Use filenames with a maximum of 8 characters (letters and digits only) and use a 3 character extension. Note that lowercase and uppercase are perceived as the same. This error will also occur if you attempt to delete a nonexistent file.
- 609 Media is not writable  
A save was attempted to a read-only device.
- 610 File access is denied  
The file is protected or hidden and cannot be accessed.
- 612 File not found  
The analyzer could not find the specified file.

- 613 Flash memory is full  
**The internal flash memory is full. Clear some space by deleting unwanted files. If your analyzer has a serial number less than US41440000 or MY41440000 and Option B72 has not been installed, you may also increase the flash memory size by purchasing Option B72.**
- 614 Bad or missing floppy disk  
**The floppy is not inserted or the directory could not be read. Insert a known good disk and try again.**
- 615 Corrupted file  
**The file that you were trying to load is corrupt.**
- 617 Wrong density floppy inserted  
**The floppy disk has the wrong density. It should be 1.44 MB.**
- 618 Illegal write access of Flash memory  
**Attempt to write to an unavailable area of internal flash memory.**
- 619 Can't Auto-Couple RBW in Zero Span  
**You sent a remote command to set the RBW into auto while in zero span. (Remote interface only.)**
- 620 Can't Auto-Couple Sweep Time in Zero Span  
**You sent a remote command to set the sweep time to auto while in zero span. (Remote interface only.)**
- 651 Connect RF OUT to INPUT  
**Attempt to align the tracking generator without its output connected. Connect the tracking generator RF OUT to the analyzer INPUT.**

- 652                   Connect Amptd Ref Output to Input
- For Agilent Technologies E4402B, E4403B, E4404B, E4405B, E4407B, and E4408B only: you must connect the **AMPTD REF OUTPUT** to the analyzer **INPUT** with the appropriate cable.*
- 653                   Auto Align not available when using Calibration Defaults
- The Auto Alignment system cannot be used until an **Align Now All** is executed by pressing **System, Alignments, Align Now, All**. On all Agilent Technologies ESA spectrum analyzer models except Agilent Technologies E4401B and E4411B, you must connect the **AMPTD REF OUT** to the **INPUT** with the appropriate cable to perform this alignment. *For Agilent Technologies E4401B and E4411B only: disconnect any signals from the **INPUT** prior to performing this procedure.*
- 701                   Invalid printer response
- In attempting to identify the printer an invalid response was received. Check that you are using a supported printer. Be sure you are using the proper cable and that it is securely fastened.
- 702                   Unsupported printer
- A printer which is recognized, but known to be unsupported was identified. This printer cannot be used with the analyzer. For example, a printer only supported by Microsoft Windows will generate this error.
- 703                   Unknown printer
- In attempting to identify the printer, a valid response was received but the printer is not known to the analyzer. Use the **Custom** printer menu under **Print Setup** to configure the printer.



- 704 Printer interface error  
An error occurred while trying to print. Make sure the printer is turned on and properly connected.
- 705 Printer Type is None  
The current printer type is set to **None**, so no print operations are possible. Change the type in the **Print Setup** menu and try again.
- 727 In <filename>: [DATA] header missing  
This message indicates that the data section of a file did not begin with the token [DATA].
- 728 In <filename>, line <nnn>: separator missing  
The [HEADER] section of a file contains entries requiring an equal (=) sign, such as <keyword> = <value>. This message appears if the equal sign does not appear on the line.
- 729 In <filename>: error reading file  
Appears when loading data from a limit line or corrections disk file and a failure to the file occurs.
- 730 In <filename>, line <numeric\_value>: line too long  
When loading data from a limit line or corrections disk file, this message will appear if the length of any line in the file exceeds 255 characters.
- 731 In <command>: bad data count (<numeric\_value>): expected multiple of <numeric\_value>  
This message indicates that the data sent to a corrections or limit table via the **DATA** or **MERGE** commands does not have the expected length for the table. For example, this message would appear if an attempt were made to merge 7 numeric values into a limit table, since each logical entry requires 3 values (frequency, amplitude, and connected).

- 732            In <filename>, line <numeric\_value>: error parsing tokens
- This message may appear when loading data from a limit line or corrections disk file. It indicates a problem in the attempt to break a string of text into tokens. There may be too few tokens in the string. In other words, the file content must match the expected format. This typically happens when there are too few numeric values in the [DATA] section of a limit or corrections file.
- 733            In <filename>, line <numeric\_value>: <xxx> is not numeric
- This message may appear when loading data from a limit line or corrections disk file. It indicates that a non-numeric token <xxx> was found where a numeric token was expected. In other words, the file content must match the expected format.
- 734            Interpolation error: cannot compute log of <negative\_frequency\_value>
- Occurs when the frequency interpolation of a limit line is set to log and the start frequency of the instrument is negative. The <negative\_frequency\_value> is limited to - 80 MHz, so it may not match the frequency that caused the error.
- 735            In <filename>: bad amplitude unit <unit>
- This message indicates that unit <unit> is not recognized or supported.
- 736            Too many data values at <freq\_or\_time\_value>
- This message may appear when data is sent to a corrections or limit table using the **DATA** or **MERGE** commands. These tables limit the number of amplitudes associated with a frequency or time to 2 or less. This message will appear if an attempt is made to attach 3 or more values to a frequency or time.

- 751 Instrument state may be corrupt, state has been reset to initial values  
**An error in the internal instrument state has been detected. The state has been reset to a default value.**
- 752 Unable to load state from file  
**Loading of state from a file failed.**
- 753 Unable to save state to file  
**Saving of state to a file failed.**
- 755 Unable to load state from register  
**Loading a state from an internal state register failed.**
- 756 Unable to save state to register  
**Saving of state to an internal register failed.**
- 757 Unable to load user state, factory preset was done  
**An attempt to perform a User Preset failed, so the Factory Preset values were used. Save a valid state into User Preset and try again.**
- 758 Unable to save user state  
**An attempt to save to the User Preset state failed.**
- 759 Unable to load state  
**A saved state file from a newer firmware revision was attempted to be loaded into an older instrument.**
- 760 Unable to query state  
**Query of state over the remote interface was unsuccessful.**

- 761           Unable to set state  
**Attempt to set the state over the remote interface was unsuccessful.**
- 762           Incorrect filename, allowable extensions  
              are .trc or .csv  
**Attempt to save a trace to a file with an incorrect  
extension.**
- 762           Unable to load file  
**A failure occurred while loading a file; the file was not  
loaded.**
- 763           Incorrect filename, allowable extensions  
              are .gif or .wmf  
**Attempt to save a screen image to a file with an  
incorrect extension.**
- 764           Unable to save file  
**A failure occurred while saving a file; the file was not  
saved.**
- 769           Invalid instrument mode  
**You have attempted to switch to an instrument mode  
that is currently not installed. Confirm that the mode  
name (for INST:SEL) or number (for INST:NSEL) was  
entered correctly and that the requested personality is  
actually installed in the instrument.**
- 770           Instrument mode requested is not supported  
**Instrument mode specified with: INST command is not  
valid. Refer to Chapter 5, “Instrument Subsystem” of  
*Agilent Technologies ESA Series Spectrum Analyzer  
Programmer’s Guide* for more information.**

- 771 Store Ref trace before turning on Normalize  
A reference trace must be available for the Normalize function to be activated. Refer to “View/Trace” in the Agilent ESA Spectrum Analyzer User’s Guide where the **Normalize** key function is explained in detail.
- 772 Cannot load a directory, please choose a file  
You have selected a directory instead of a file when attempting to perform the Load function under the **File** front-panel key.

### Greater than 10000: Measurement Applications Errors

---

NOTE Error numbers are displayed in the error queue, *not* on the display.  
To see an error *number*, view the error queue as described on [page 17](#).

---

- 10010 One or more harmonics beyond freq limit:  
number decreased.  
**Highest harmonic was past the frequency limit of the analyzer, so the number of measured harmonics was decreased.**
- 10011 Second harmonic is beyond analyzer frequency limit.  
**The frequency range of your analyzer does not include the first multiple of the captured fundamental frequency in internal mixing.**
- 10012 No Fundamental > 0 Hz found in given span.  
**There were no frequencies greater than 0 Hz in the starting span, so the measurement was stopped.**
- 10013 No Fundamental > -50 dBm found in given span.  
**A fundamental was not found, so the measurement was stopped.**

- 10138** Valid GSM burst not found in frame (Burst Type).  
**No active GSM bursts that match the selected Burst Type have been detected in the RF input signal. The search was performed over the complete GSM frame.**
- 10139** Valid GSM burst not found in specified timeslot (Burst Type).  
**No active GSM bursts that match the selected Burst Type have been detected in the RF input signal. The search was only performed over the specified timeslot setting.**
- 10140** Valid GSM burst not found in frame (Ref Burst).  
**No active GSM bursts that match the selected Burst Type have been detected in the RF input signal. The search was performed using the Ref Burst type setting over the complete GSM frame.**
- 10141** Sync word not found in frame (Burst Type)  
**One or more active GSM bursts that match the selected Burst Type have been detected in the RF Input signal, but none contain the selected Training Sequence Code (TSC). The search was performed over the complete GSM frame.**
- 10142** Sync word not found in specified timeslot (Burst Type)  
**One or more active GSM bursts that match the selected Burst Type have been detected in the RF Input signal, but none contain the selected Training Sequence Code (TSC). The search was only performed over the specified timeslot setting.**
- 10143** Sync word not found in frame (Ref Burst)  
**One or more active GSM bursts that match the selected Burst Type have been detected in the RF Input signal, but none contain the selected Training Sequence Code (TSC). The search was only performed using the Reference Burst type and Reference TSC settings over the complete GSM frame.**

- 10144           Unknown demod status.  
  
Demodulation is in an unknown state. Press **Preset**. If the error persists, get in touch with your service center.
- 10145           Opt AYX hardware required. Meas unavailable.  
  
Option AYX must be installed for this measurement to be enabled.
- 10146           Opt B7D & B7E hardware required. Meas unavailable.  
  
The RF Communications Hardware (Option B7E) and Digital Signal Fast ADC (Option B7D) cards required to perform the demodulation are not present in the analyzer.
- 10147           Opt B7D bootrom requires upgrade.  
  
The (Option B7D) bootrom revision is not supported by the currently loaded personality version. Refer to the user's guide for the personality in use.
- 10148           Opt BAH DSP algorithm files not installed. Meas unavailable.  
  
The Digital Signal Processor algorithm files required to perform the demodulation are not present in the analyzer.
- 10149           Opt BAH DSP algorithm code file requires upgrade.  
  
The Digital Signal Processing algorithm code file revision is not supported by the currently loaded personality version. Refer to the user's guide for the personality in use for more information on installation/upgrade.

- 10150** Opt BAH DSP algorithm coef. file requires upgrade.  
**The Digital Signal Processor algorithm coefficient file revision is not supported by the currently loaded personality version. Refer to the user's guide for the personality in use.**
- 10151** Opt BAH DSP algorithm files failed to load, aborting measure.  
**The Digital Signal Processor algorithm files required to perform the demodulation are corrupt and cannot be loaded properly. Reinstall measurement personality.**
- 10152** Lost trigger, aborting measurement.  
**The selected trigger source was present at the start of the measurement, but timed out before the measurement completed.**
- 10153** DSP algorithm timeout, aborting measurement  
**The Digital Signal Processor demodulation algorithm timed-out for an unknown reason. This message normally indicates a problem with the modulated signal.**
- 10154** Measurement not defined for Out of Band.  
**You have changed to an out-of-band frequency range. The band measurement only operates in the selected band.**
- 10155** No Fast ADC hardware installed. Meas unavailable.  
**The analyzer cannot use sweep times of less than 5 msec when Option B7D or Option AYX is not installed. Therefore the measurement will not be executed.**
- 10156** No Fast ADC hardware installed.  
**The analyzer cannot use sweep times of less than 5 msec when Option B7D or Option AYX is not installed resulting in all the radio standards not being supported.**



- 10157            Tracking Generator hardware is not present.  
                 Meas unavailable.  
  
                 **The measurement requires a built-in tracking  
                 generator.**
- 10159            Entire trace is below threshold level  
  
                 **The measurement cannot operate properly because the  
                 trace has completely fallen below the threshold level.  
                 Change the threshold level to view trace.**
- 10160            Upper Custom Mask is Invalid!  
  
                 **The user-specified upper custom mask cannot be  
                 resolved into a limit line. The format is incorrect.**
- 10161            Lower Custom Mask is Invalid!  
  
                 **The user-specified lower custom mask cannot be  
                 resolved into a limit line.**
- 10162            Resolution BW <300 kHz.  
  
                 **This error message is a warning that the resolution  
                 bandwidth has been set below 300 kHz. The test results  
                 will not meet GSM specifications.**
- 10163            Cannot find the Power vs Time Limits File.  
  
                 **The limit line definition file for the GSM standards has  
                 been deleted. This message is displayed while the  
                 **Measure** key is grayed out. Reinstall the GSM  
                 measurement personality.**
- 10164            Band Measurement not defined for Out of Band.  
  
                 **You are attempting to monitor the band but have set  
                 the frequency outside the band. Reset the band for the  
                 particular standard for which you are testing or use the  
                 channel setting which does not require a frequency to  
                 be set. (**Meas Setup, Method (Channel)**).**

- 10166**            Cannot update the list of cable types.  
**The cable file may have been moved or deleted accidentally. Reinstall the measurement personality. This message is applicable to the GSM (Option BAH) and Distance to Fault (Option 226) measurement personality options.**
- 10168**            Cannot update the list of cable types on drive C:  
**The file update failed.**
- 10170**            The Cable Fault Measurement is active. Mode Setup is disabled.  
**Mode setup is not available in the cable fault utility.**
- 10172**            Sweep Time too fast (<2 sec)  
**The sweep time must be set to 2 seconds or longer for the results to be valid.**
- 10177**            There are no spurs to inspect.  
**You have attempted to switch the **Inspect Spur** softkey to the **On** position after the measurement has finished, but found no spurs.**
- 10179**            Carrier Present. Test Stopped!  
**A carrier was found in the transmit band. Either disable the carrier or insert a bandpass filter for the receive bandwidth.**
- 10180**            Gate option not installed. Results may not be accurate.  
**This measurement method requires the use of the time-gate (option 1D6) in order to gate the spectrum during the 50-90% part of the burst. If the gate option is not installed, the measurement will still run although this warning will be displayed.**

- 10186 Measurement does not support the current radio standard.
- The measurement you have chosen is currently greyed out. Select a radio standard which is supported (**Mode Setup, Radio Std**) or configure the measurement manually.
- 10187 Radio standard is not supported by the current measurement.
- The standard you have chosen is currently greyed out. Select a radio standard which is supported by the current measurement (**Mode Setup, Radio Std**) or configure the measurement manually.
- 10218 Hardkeys are disabled.
- Some of the forms (for example Receiver Spurious in GSM) do not allow you to close the form without either formally accepting or cancelling the form settings. For this reason, all of the hardkeys are disabled until you terminate the form.
- 10219 Awaiting trigger
- The measurement requires a trigger to be present. If the trigger does not occur or is delayed, this message will be displayed. Check your trigger settings.
- 10227 Measurement suspended until carrier is turned off.
- The receive channel power and the receive spur measurements are specified with the attenuation set to 0 dB. To prevent overload, the frequency spectrum of interest is monitored for signal levels which exceed a specified threshold before setting the attenuator to 0 dB. If a carrier is found, this message is displayed and the completion of the measurement will not occur until the carrier is removed. The carrier check may be turned off using the properties form under the front-panel **Mode Setup** key. You may also change the signal threshold which determines a carrier on the properties form.

- 10228**            Cannot correlate to input signal.
- This error is normally generated because of one of the following reasons:**
- 1. There is no carrier signal.**
  - 2. Walsh channels other than the pilot are active.**
  - 3. There is some other modulation problem that will prevent the measurement from being made.**
- This problem must be corrected before the measurement can continue.**
- 
- 10229**            The regression portion failed.
- This message occurs when (Option B7D) is not functioning properly. Demodulation measurements (modulation accuracy and code domain) might fail as a result of this error.**
- 
- 10230**            DSP timed out, resetting DSP.
- Digital Signal Processor was unable to finish the selected measurement within the given period of time. Restart the measurement.**
- 
- 10231**            Measurement failed for unknown reasons.
- Check instrument settings and restart measurement.**
- 
- 10232**            RF Signal not found.
- This message is generated if there is no signal at the center frequency that is greater than 10 dB above the displayed average noise level.**
- 
- 10233**            Level is low, results may degrade.
- The signal being measured is of low power. The results may not be as accurate as they would be if the signal level was higher.**
- 
- 10237**            RF Board LO Unlocked. Contact service center.
- This message occurs if the local oscillator on the (Option B7E) is in an unlocked state. This indicates broken hardware.**

- 10238** RF Board SR Osc Unlocked. Contact service center.
- This message occurs if the sample rate (SR) oscillator on Option B7E is in an unlocked state. This indicates broken hardware.
- 10239** Opt Freq Ref setting does not match external reference.
- This message is generated if Source is set to External on the properties form under the front-panel **Mode Setup** key and the frequency on the same form is set to a frequency that does not match the frequency of the signal being used as the external reference.
- 10240** RF Board RF Osc Unlocked. Contact service center.
- This message occurs if the reference oscillator on the (Option B7E) is in an unlocked state. This indicates broken hardware.
- 10241** RF Board could not detect any bursts in signal.
- This message is generated when the trigger is set to RF Burst and (Option B7E) cannot detect a burst.
- 10245** Error reading file: SPCLIMIT.CSV. Cannot use custom limits.
- The file could be missing or corrupt. Create a new limits file. Alternatively, the actual limits defined in the file might not allow the measurement to be executed. Redefine the limits or use the default limits. Restart the measurement.
- 10246** Error reading file: CDMASTUN.CSV. Please reinstall cdmaOne.
- The file is missing or corrupt. Please reinstall the cdmaOne personality.

10247 Error reading file: CDPDMDA. Please reinstall cdmaOne.

**The file is missing or corrupt. Please reinstall the cdmaOne personality.**

10248 Error reading file: CDPPMCO. Please reinstall cdmaOne.

**The file is missing or corrupt. Please reinstall the cdmaOne personality.**

10249 Error reading file: CDPPMDA. Please reinstall cdmaOne.

**The file is missing or corrupt. Please reinstall the cdmaOne personality.**

10250 Error reading file: RHODMDA. Please reinstall cdmaOne.

**The file is missing or corrupt. Please reinstall the cdmaOne personality.**

10251 Error reading file: RHOPMCO. Please reinstall cdmaOne.

**The file is missing or corrupt. Please reinstall the cdmaOne personality.**

10256 Error reading file: OOBSTAB.CSV. Use Edit Table | Save Table.

**This error is generated when you try to load a table (using the **Load Table** key on page 2 of the edit table form menu) before a table has been saved. You must first save a table using the **Save Table** key before trying to load a table using the **Load Table** key.**

10259 Table could not be saved.

**This message occurs if the C: drive is full or corrupt. Check the amount of space left on the drive.**

- 10260            Table could not be loaded.
- When trying to load a table, the previous table has been somehow corrupted. Use the **Save Table** key to save a valid table. Then edit the valid table, save it, and try to load it again.
- 10264            Emission bandwidth not found. Consider increasing span.
- This error is normally generated when attempting occupied bandwidth measurements. The “X dB” value you entered (**Meas Setup, X dB**) to calculate the emission bandwidth is the difference between the highest point on the trace and the point “X dB” down on either side of the maximum. If the actual difference is less than the value entered, the emission bandwidth cannot be computed. Some responses to this situation are as follows:
1. Connect a signal to the input. (If there is no signal present, the difference between the trace minimum and maximum will generally be less than “X dB”.)
  2. Increase the span. (If the signal is wide, the shoulders of the signal might not be present on the screen, and again, the difference between the trace minimum and maximum will be less than “X dB”.)
  3. Center the signal. (There must be a point on the trace that is “X dB” down from the maximum on both sides of that maximum.)
- 10286            Burst not found.
- The signal being analyzed has insufficient power, the rising or falling edges cannot be detected, or the burst is less than 120 microseconds.
- 10287            Valid Bluetooth burst not found. (Check Packet Type)
- The burst that has been found does not correspond to the currently selected Bluetooth packet type (the burst length may be too short).

- 10288** Opt B7D or AYX FADC hardware required. Meas unavailable.  
**The measurement you are attempting requires either the DSP and Fast ADC (Option B7D) or the Fast ADC (Option AYX) card to perform the demodulation, but neither are present in the analyzer.**
- 10289** Opt 106 demod hardware required. Meas unavailable.  
**A demod measurement was attempted with no Bluetooth FM demod card present (Option 106).**
- 10290** Parameter unavailable in demod measurements.  
**You have selected (by remote SCPI command) either RF Amplitude sync or Video trigger while running one of the demod measurements.**
- 10291** Opt B7E RF hardware required. RF Burst unavailable.  
**You have selected (by remote SCPI command) RF Burst Trigger with no digital demodulation RF card present (RF Communications Hardware (Option B7E)).**
- 10320** Opt 106 hardware required. Preamble sync unavailable.  
**You have selected (by remote SCPI command) preamble sync with no Bluetooth FM demodulation card present (Option 106).**
- 10321** Start Marker must be at least 1% < Stop Marker.  
**You have attempted to input a start marker value that will result in the difference between the start and stop markers being less than 1%.**
- 10322** Stop Marker must be at least 1% > Start Marker.  
**You have attempted to input a stop marker value that will result in the difference between the start and stop markers being less than 1%.**



- 10323** Unable to Calculate Result using Current Setup.  
**You have changed the setup parameters such that the marker lines used to measure the power cannot be displayed therefore accurate measurements cannot be made.**
- 10340** '10101010' pattern not detected - results may be inaccurate.  
**This message is displayed if the measurement cannot detect the '10101010' pattern in the payload. The measurement will continue and carry out the calculations on the payload data supplied, but may not be correct.**
- 10350** Payload data pattern '10101010' not present.  
**This message is displayed when the "Payload Data" parameter is set to Auto and the measurement has not detected either of the required patterns in the payload.**
- 10351** Required payload data pattern '10101010' not present.  
**This message is displayed after successfully measuring and holding the '11110000' pattern if the measurement is restarted and the '10101010' data pattern is not detected.**
- 10352** Required payload data pattern '11110000' not present.  
**This message is displayed after successfully measuring and holding the '10101010' pattern if the measurement is restarted and the '11110000' data pattern is not detected.**
- 10353** There is no valid result to hold.  
**You have attempted to hold either  $\Delta f1$  or  $\Delta f2$  before it has been measured.**

- 10360** Can't compute result - not enough transitions.  
**This message is displayed when the measurement cannot find either a 111, 000, 101 or 010 pattern and is therefore unable to calculate the low or high frequency deviations.**
- 10400** Valid signal not found.  
**This error is normally generated because of one of the following reasons:**
- 1. There is no carrier signal.**
  - 2. The carrier signal power has changed during the measurement, causing ADC to over/under range.**
  - 3. There is some other modulation problem that will prevent the measurement from being made. This problem must be corrected before the measurement can continue.**
- 10401** Valid burst not found in frame (Burst Type).  
**No active bursts that match the Burst Type have been detected in the RF input signal. The search was performed over the complete frame.**
- 10402** Valid burst not found in specified timeslot (Burst Type).  
**No active bursts that match the Burst Type have been detected in the RF input signal. The search was only performed over the specified timeslot setting.**
- 10403** Sync word not found in frame (TSC).  
**One or more active EDGE bursts that match the Normal Burst Type have been detected in the RF Input signal, but none contain the selected Training Sequence Code (TSC). The search was performed over the complete EDGE frame.**

- 10404 Sync word not found in specified timeslot (TSC).  
**One or more active EDGE bursts that match the Normal Burst Type have been detected in the RF Input signal, but none contain the selected Training Sequence Code (TSC). The search was only performed over the specified timeslot setting.**
- 10409 Wideband calibration not valid until Align Now, All performed.  
**Wideband calibration corrections cannot be applied to current demodulation results. Results will not meet specified demodulation performance levels until an Align Now, All has been performed.**
- 10410 Measurement uncalibrated, wideband calibration required.  
**Wideband calibration corrections cannot be applied to the current demodulation results. Results will not meet specified demodulation performance levels until **Wideband Cal** has been selected and successfully performed.**
- 10411 Measurement uncalibrated, symbol rate exceeds +/-10% nominal.  
**Wideband calibration corrections cannot be applied to current demodulation results, due to the **Symbol Rate** setting exceeding +/-10% of the nominal value. Results may not meet specified demodulation performance levels.**
- 10412 Cal Data corrupt. Wideband cal failed. Using previous data.  
**Wideband calibration procedure failed for an unknown reason. New calibration data was not saved. Previous wideband calibration data is being used, if available. However, it is not acceptable. Before re-attempting Wideband Cal, ensure connection between the **AMPTD REF OUT** and the **INPUT 50 Ω** is in place. If the error persists, get in touch with your service center.**

- 10413** B7D DSP Code Install Fail Opt.229.Contact your Service Center.  
**The Digital Signal Processor algorithm files required to perform the demodulation are not present in the analyzer. Reinstall the measurement personality and contact your service center.**
- 10414** Opt 229 DSP algorithm code file requires upgrade.  
**The Digital Signal Processing algorithm code file revision is not supported by the currently loaded personality version. Refer to the user's guide for the personality in use for more information on installation/upgrade.**
- 10415** Opt 229 DSP algorithm coef. file requires upgrade.  
**The Digital Signal Processor algorithm coefficient file revision is not supported by the currently loaded personality version. Refer to the user's guide for the personality in use for more information on installation/upgrade.**
- 10416** B7D DSP Code Reload Fail Opt.229.Contact your Service Center.  
**The Digital Signal Processor algorithm files required to perform the demodulation are corrupt and cannot be loaded properly. Reinstall the measurement personality and contact your service center.**
- 10417** This operation requires a measurement to be active.  
**The analyzer cannot perform this operation, because it requires a measurement to be running and no measurement is running.**
- 10418** Demod Format setting does not allow this value for Points/Symbol.  
**Invalid Points/Symbol selection attempted for the given Demod Format setting.**

- 10419 Carrier Not Present.  
A carrier signal/burst is expected at the analyzer input. This signal cannot be found; however, the measurement will still run. Check input signal connection.
- 10420 Valid burst not found.  
This error only occurs when **RF Amptd** is selected for **Burst Sync**. It indicates that a valid burst envelope which meets the specified Burst Search Threshold was not found within the specified Burst Search Length. Note that the demodulation measurement will proceed by attempting to demodulate the signal without Burst Sync alignment. Possible causes may be:
1. Carrier signal is not actually bursted.
  2. Burst Search Threshold and/or Burst Search Length may need to be adjusted.
- 10421 Cannot lock to carrier.  
This error only occurs when attempting to demodulate **OFFSET QPSK** signals. It indicates that the demodulation algorithm is unable to lock to your signal. Possible causes may be:
1. There is no carrier signal.
  2. Carrier signal is present, but Demod settings do not match the modulation format of the **OFFSET QPSK** signal being measured.
  3. **OFFSET QPSK** signal is too noisy to achieve carrier lock.
- 10425 B7D DSP Code Install Fail Opt.231.Contact your Service Center.  
The Digital Signal Processor algorithm files required to for the 89600 VSA SW are not present in the analyzer. Reinstall the measurement personality and contact your service center.

- 10426** Opt 231 DSP algorithm code file requires upgrade.  
**The Digital Signal Processing algorithm code file revision is not supported by the currently loaded personality version. Refer to the user's guide for the personality in use for more information on installation/upgrade.**
- 10427** Opt 231 DSP algorithm coef. file requires upgrade.  
**The Digital Signal Processor algorithm coefficient file revision is not supported by the currently loaded personality version. Refer to the user's guide for the personality in use for more information on installation/upgrade.**
- 10428** B7D DSP Code Reload Fail. Opt.231.Contact your Service Center.  
**The Digital Signal Processor algorithm files required for the 89600 VSA SW are corrupt and cannot be loaded properly. Reinstall the measurement personality and contact your service center.**
- 10450** Avg Mode changed to Repeat for Full Meas Type.  
**Avg Mode and Meas Type are coupled. Selecting Full Meas Type forces Repeat Avg Mode.**
- 10451** Avg Mode changed to Exp for Examine Meas Type.  
**Avg Mode and Meas Type are coupled. Selecting Examine Meas Type forces Exp Avg Mode.**
- 10452** Meas Type changed to Examine for Exp Avg Mode.  
**Avg Mode and Meas Type are coupled. Selecting Exp Avg Mode forces Examine Meas Type.**

- 10453** Meas Type changed to Full for Repeat Avg Mode.  
**Avg Mode and Meas Type are coupled. Selecting Repeat Avg Mode forces Full Meas Type.**
- 10511** 100 spurs found. Additional spurs ignored.  
**The maximum number of spurs have been found. Any additional spurs found during this measurement will not be logged.**
- 10512** No spurs have been found.  
**There were no spurs found using the current range setup.**
- 10513** No ranges are defined.  
**All ranges are currently set to off.**
- 10524** This measurement does not support the \*.CSV file format.  
**You cannot load CSV format trace files or save traces in the CSV format in the Log Plot measurement of the Phase Noise Measurement Personality.**
- 10525** Use View/Trace menu when loading or saving logarithmic traces.  
**You cannot load CSV format trace files or save traces in the CSV format in the Log Plot measurement of the Phase Noise Measurement Personality.**
- 10526** Cannot display Trace because it contains no data.  
**Reference trace cannot be displayed, as there is currently no data assigned to it - use the functions under the Store Ref Trace menu, or load a trace to assign some data.**

- 10527** Invalid Marker Trace.  
Cannot place markers on the reference trace, because the reference trace is currently turned off or has no data.
- 10529** Failed to Load trace. Bad file format.  
The load trace operation could not be completed, as the input file was not in the expected format. You can only load traces that were previously saved using the 'Save Trace' feature.
- 10530** Trace file contains no compatible traces.  
The trace file may have been created by another version of the Phase Noise personality, which uses a different trace format that is incompatible with the version you are running. Please check you are running the most up to date version of the personality.
- 10531** Trace file was created by incompatible version of Opt. 226  
The trace file may have been created by another version of the Phase Noise personality, which uses a different trace format that is incompatible with the version you are running. Please check you are running the most up to date version of the personality.
- 10532** Cannot open trace file for writing. Save Failed.  
Cannot write the trace file to the destination filename. This could be because the disk is full, or possibly due to a filename error. If using a floppy disk, check there is a formatted disk in the drive.
- 10533** Cannot save Trace because it contains no data.  
Check the Ref Trace is turned on, and contains some valid trace data.



- 10534 Trace file saved successfully.  
**The trace saving operation was successful.**
- 10535 Cancellation trace is not set to Reference or has no data.  
**When performing phase noise cancellation, you need to supply a reference trace that will be used to cancel out the background noise of the analyzer. The reference trace must be in Reference (View) mode, and selected by the Ref Trace parameter under the Cancellation menu.**
- 10536 Cancellation disabled while measuring DANL Floor.  
**Phase Noise cancellation does not make sense when measuring the DANL Floor, so for this reason it has been disabled.**
- 10537 10537 Cancellation trace has different X-Scale to Smoothed trace.  
**When performing phase noise cancellation, you need to supply a reference trace that will be used to cancel out the background noise of the analyzer. The reference trace must have been measured over the same range of offsets, and on the same instrument as the current measurement being performed.**
- 10560 Carrier Not Present. Verify frequency and amplitude settings.  
**No Carrier > -50 dBm found at the analyzer input within the search span. Solution: Modify center frequency to be closer to actual carrier, or alternatively apply carrier of sufficient amplitude at the current center frequency.**
- 10561 Signal Tracking disabled when measuring DANL Floor (Removal).  
**Measuring the DANL Floor with DANL Method set to Removal requires that the user remove the signal and attach a load to the analyzer RF Input. Signal Tracking requires that the carrier be measured many times per measurement, so the two are inherently incompatible.**

## Instrument Messages without Numbers

### Error Messages

Unable to uninstall personality, file not deletable.

This message occurs when you try to delete a personality which has been marked as non-deletable. The personality is marked non-deletable at the factory. Get in touch with your nearest service center for further assistance.

### Status Messages

Status \* (Invalid Data)

This indicator is displayed when data on the screen may not match the screen annotation, for example while analyzer settings are changing or when any trace is in view mode.

Status 50 MHz Osc Unlevel (50 MHz Osc Unleveled)

The internal 50 MHz amplitude reference source has become unlevelled. This condition must be corrected before a valid alignment can be performed.

Status (ADC Align Failure)

A status bit only, no message. The alignment routine was unable to align the analog-to-digital converter (ADC).

Status Align Now All Needed (Align Needed)

The instrument requires complete alignment. Press **System, Alignments, Align Now, All**. On all Agilent Technologies ESA spectrum analyzer models except Agilent Technologies E4401B and E4411B, you must connect the **AMPTD REF OUT** to the **INPUT** with the appropriate cable to perform this alignment. *For Agilent Technologies E4401B and E4411B only:* disconnect any signals from the **INPUT** prior to performing this procedure. If this message recurs, load defaults (**System, Alignments, Load Defaults**) and then perform **Alignment Now, All**.

Status	<p>Align Now RF Needed (Align Now RF Needed)</p> <p>The instrument requires RF alignment. Press <b>System, Alignments, Align Now, RF (EXT Cable)</b>. On all Agilent Technologies ESA spectrum analyzer models except Agilent Technologies E4401B and E4411B, you must connect the <b>AMPTD REF OUT</b> to the <b>INPUT</b> with the appropriate cable to perform this alignment. <i>For Agilent Technologies E4401B and E4411B only:</i> disconnect any signals from the <b>INPUT</b> prior to performing this procedure.</p>
Status	<p>Align RF Skipped (Align RF Skipped)</p> <p>The RF alignment has been skipped because a 50 MHz signal was detected at the <b>INPUT</b>; alignment will resume when the 50 MHz signal is removed. The alignment will not work when there is too much input power at 50 MHz. The instrument may not continue to measure properly. To remove the message, remove the 50 MHz input signal, then perform an <b>Align Now, RF</b>. Press <b>System, Alignments, Align Now, RF</b>. On all Agilent Technologies ESA spectrum analyzer models except E4401B and E4411B, you must connect the <b>AMPTD REF OUT</b> to the <b>INPUT</b> with the appropriate cable to perform this alignment. <i>For Agilent Technologies E4401B and E4411B only:</i> disconnect any signals from the <b>INPUT</b> prior to performing this procedure.</p> <p>If this message occurs and you are going to make a measurement near 50 MHz, select <b>System, Alignments, Auto Align</b>, and <b>All but RF</b>.</p>
Status	<p>DC Coupled</p> <p>Indicates the input of the analyzer is DC coupled (<b>Input/Output, Coupling (DC)</b>). This setting is necessary when measuring frequencies below 100 kHz on E4402B with Option UKB, E4404B, and E4405B analyzers. For E4407B analyzers with Option UKB, you must set the coupling to DC when measuring below 10 MHz. Take care to limit the input level to 0 Vdc and +30 dBm whenever you are in DC coupled mode.</p>

<b>Status</b>	Demod ON: reduce span for audible detection  <b>When the Demod function is active and the speaker is turned on, the ratio of the resolution bandwidth to span must be greater than 0.002 to properly demodulate and listen to the resulting audio signal. You must decrease the span to continue the measurement</b>
<b>Status</b>	Ext Ref (no corresponding status bit)  <b>Indicates that the frequency reference is being supplied by an external 10 MHz source.</b>
<b>Status</b>	Flat corr off (no corresponding status bit)  <b>Indicates that the flatness corrections have been turned off.</b>
<b>Status</b>	(FM Demod Align Failure) status bit only, no message  <b>A failure has occurred during the FM Demod alignment. Measurement results may be invalid.</b>
<b>Status</b>	Freq corr off (no corresponding status bit)  <b>Indicates that the frequency corrections have been manually disabled. Press <b>System, Alignments, Freq Correct, (On)</b> to restore.</b>
<b>Status</b>	Frequency Reference Error (Freq Ref Unlocked)  <b>The frequency reference has been tuned too far off of 10 MHz. This condition may be corrected by cycling power on the analyzer.</b>
<b>Status</b>	(IF Align Failure) status bit only, no message  <b>A failure has occurred during the IF alignment. Measurement results may be invalid.</b>

Status	IF Gain fixed  The autoranging function of the analyzer has been turned off ( <b>Amplitude, More, More, IF Gain (Fixed)</b> ). This setting is useful when measuring signals that require fast measurement time, narrow resolution bandwidths (< 1 kHz), and < 70 dB of display range. For more information on this setting, refer to IF Gain key description in the <i>ESA Spectrum Analyzer User's Guide</i> .
Status	IF Overload (IF/ADC Over Range)  The IF section has been overloaded. Measurement results may be invalid.
Status	Input is internal (no corresponding status bit)  <i>This message applies to the Agilent Technologies E4401B and E4411B only.</i> Indicates the <b>50 MHz Amptd Ref</b> selection is <b>On</b> . With the 50 MHz amplitude reference on, the input is routed through an internal signal path.
Status	(LO Align Failure) status bit only, no message  A failure has occurred during the alignment of the local oscillator (LO). Measurement results may be invalid.
Status	LO Out Unlevel (LO Out Unleveled)  Indicates the output of the local oscillator (LO) has become unlevelled. This condition must be corrected to make valid measurements.
Status	LO Unlevel (LO Unleveled)  Indicates the internal circuitry of the local oscillator (LO) has become unlevelled. This condition must be corrected to make valid measurements.

<b>Status</b>	LO Unlock (Synth Unlocked)  Indicates the phase locked circuitry of the local oscillator (LO) has become unlocked. This condition must be corrected to make valid measurements.
<b>Status</b>	Log Corr Off (no corresponding status bit)  The log amplifier corrections have been turned off.
<b>Status</b>	Marker Count:Widen Res BW  The ratio of the resolution bandwidth to span must be greater than 0.002 for the marker count function to work properly. Increase the resolution bandwidth or decrease the span to continue the measurement.
<b>Status</b>	Meas Uncal (Oversweep)  The measurement is uncalibrated. Check the sweep time, span and bandwidth settings, or press <b>Auto Couple</b> and <b>Auto All</b> .
<b>Status</b>	Overload: Reduce Signal and press <ESC> (Input Overload Tripped)  <i>This message applies to the Agilent Technologies E4401B and E4411B only.</i> A signal has been applied to the input connector that caused the overload protection circuitry to engage. The input signal must be reduced. After the signal is reduced, press <b>ESC</b> to reset the overload detector so that you can continue using the analyzer.

---

**CAUTION**

---

Exposing the analyzer to high levels of input power over a prolonged period of time can damage the internal circuitry.

<b>Status</b>	Peaking Signal (no corresponding status bit)  The instrument is executing a tracking generator peak.
<b>Status</b>	Preferred resolution bandwidth not available.  The calculated required resolution bandwidth for this measurement is not available.

Status	(RF Align Failure) status bit only, no message  A failure has occurred during the alignment of the RF section. Measurement results may be invalid.
Status	Signal Ident On, Amptd Uncal (Signal Ident On)  Indicates that the amplitude measurement could be uncalibrated because the signal identification feature is on.
Status	Signal level is low.  Indicates the signal can be correlated, however the level is below that specified to ensure accurate measurement results.
Status	Source LO Unlevel (Source LO Unleveled)  The internal circuitry of the local oscillator (LO) in the tracking generator has become unlevelled. This condition must be corrected to make valid measurements.
Status	Source LO Unlock (Source Synth Unlocked)  The phase-locked circuitry of the local oscillator (LO) in the tracking generator has become unlocked. This condition must be corrected to make valid measurements.
Status	Source Unlevel (Source Unleveled)  Indicates the source power is set higher or lower than the analyzer can provide, the frequency span extends beyond the specified frequency range of the tracking generator, or the calibration data for the source is incorrect.
Status	System Alignments, Align Now, All Required  Internal alignment correction data has been lost. Press <b>System, Alignments, Align Now, All</b> to clear this message from the display.

**Status** (TG Align Failure) status bit only, no message  
A failure has occurred during the tracking generator (TG) alignment.

**Status** Video shift off (no corresponding status bit)  
Indicates the video shift has been manually disabled; this will impair readings.

### Informational Messages

**Informational** Atten auto set to 15 dB  
Indicates that an input signal has been detected which is of sufficient level to damage the input circuitry and the input attenuator has been automatically set to 15 dB. If the signal level is reduced, the attenuator will stay at 15 dB. This overload protection occurs at an input power level of 13 dBm (68 dBmV for Option 1DP)  $\pm 7$  dB when the input attenuation is auto coupled and set to <15 dB. To return to the original measurement setup, reduce the input signal level and press **Amplitude**. Then press **Attenuation (Auto)**.

Overload protection is only available in the Agilent Technologies E4401B and E4411B.

**Informational** Auto ranging...  
Displayed during autoranging.

**Informational** B7D and/or B7E not found. Code Domain not available.  
Digital Signal Processing and Fast Analog to Digital Converter (Option B7D) and/or RF Communications Hardware (Option B7E) are not installed options on your analyzer. Code domain is therefore not available.

**Informational** B7D and/or B7E not found. Mod Acc not available.  
Digital Signal Processing and Fast Analog to Digital Converter (B7D) and/or RF Communications Hardware (B7E) are not installed options on your analyzer. Modulation accuracy is therefore not available.



- Informational** Carrier Not Present.  
A carrier signal/burst is expected at the analyzer input. This signal cannot be found; however, the measurement will still run. Check input signal connection.
- Informational** Channel frequency outside device's transmit band.  
Reset channel number or frequency.
- Informational** Default spur table values loaded.  
No spur table has been previously saved when the Out-of-Band Spurious measurement begins. Press **Meas Setup, Edit Table** to enter the frequency ranges of interest and press **Save Table** to save that information. This saved table will be loaded the next time the measurement is run.
- Informational** Device = Mobile. Code Domain not available.  
Code Domain measurement is grayed out when the device is set to mobile under the **Mode Setup** front-panel key. Code Domain measurement is only accessible when the device is set to base and RF Communications Hardware (Option B7E) or Enhanced Memory Upgrade (Option B72) are installed.
- Informational** Device = Mobile. Mod Acc not available.  
Modulation accuracy measurement is grayed out when the device is set to mobile under **Mode Setup**, front-panel key. Modulation accuracy is only accessible when the device is set to base and RF Communications Hardware (Option B7E) or Enhanced Memory Upgrade (Option B72) are installed.
- Informational** <directoryname> directory deleted  
The directory indicated has been successfully deleted.

**Informational** <directoryname1> directory renamed to  
<directoryname2>  
**Directory name1 has been successfully renamed to  
directory name2.**

**Informational** Directory already exists  
**Each directory and file must have a unique name. The  
directory name you have entered is currently being  
used on the selected drive. You may either enter a new  
name or rename the directory currently existent. Refer  
to “File Menu Functions” in the Agilent *ESA Spectrum  
Analyzer User’s Guide*.**

**Informational** Entire trace is below the threshold level.  
**The measurement cannot operate properly because the  
trace has fallen completely below the threshold level.  
Change the threshold level to view signal.**

**Informational** <filename> file copied  
**The filename indicated has been successfully copied.**

**Informational** <filename> file deleted  
**The filename indicated has been successfully deleted.**

**Informational** <filename> file loaded  
**The filename indicated has been successfully loaded.**

**Informational** <filename1> file renamed to <filename2>  
**Filename1 has been successfully renamed to filename2.**

**Informational** <filename> file saved  
**The filename indicated has been successfully saved.**

**Informational** <filename> too many data entries

This message may appear when loading data from a limit line or ampcor disk file. The [DATA] section of such a file can contain at most 200 lines of data. This message is displayed if that limit is exceeded.

**Informational** Invalid format: CSV files are not supported by this measurement.

When utilizing the Phase Noise Personality: Option 226, the \*.CSV file format is not available.

**Informational** Measurement halted. Press a measurement key to continue.

This error occurs after you choose **Cancel** to refrain from setting the attenuator to 0 dB during the Receive Channel Power and Receive Spur measurements.

**Informational** No Fast ADC hardware installed. Meas unavailable.

The analyzer cannot use sweep times of less than 5 milliseconds when Option B7D or Option AYX is not installed. Therefore the measurement will not be executed.

**Informational** Not enough frequency range to measure harmonics for channel.

Selected harmonics are above the frequency range of the analyzer.

**Informational** One or more harmonics beyond freq limit: number decreased.

The highest harmonic was beyond the frequency limit of the analyzer, so the number of measured harmonics was decreased.

**Informational** Option activated

This message is displayed after entering the selected option's License Key.

**Informational** Please set RF input range (INPUT menu) to manual first.

In order to manually set the reference level and/or the attenuation under the **Amplitude** front-panel key, the RF Input Range menu under the **Input** front-panel key must be set to **Man** (manual).

**Informational** Shutdown in process.

The analyzer is responding to the **Standby** key selection, and is executing the shutdown procedure.

**Informational** Table loaded successfully.

When the **Load Table** key was pressed on the second page of the edit table form while in the out-of-band spurious measurement, the file was present. The information has been loaded into the measurement where it may be edited again. This message will also appear when the out-of-band spurious measurement is opened if a spur table has been previously saved.

**Informational** Table saved successfully.

This message appears after you press the **Save Table** key on the second page of the edit table for the out-of-band spurious measurement. It indicates that the current spur table has been written successfully to disk and is available to be loaded by means of the **Load Table** key.

**Informational** The calibration data is invalid, and has been cleared.

A parameter has changed that affects calibration. Therefore the calibration data has been reset, and for best results recalibration is recommended.

**Informational** The file containing the list of cable types has been updated.

The file update was successful.

**Informational** This measurement does not support the \*.CSV file format.

**When utilizing the Phase Noise Personality: Option 226, \*.CSV (comma separated values) file format is not available.**

**Informational** This operation requires a measurement to be active.

**The analyzer cannot perform this operation, because it requires a measurement to be running and no measurement is running.**

**Informational** Tracking Peak Needed.

**This message is displayed when there has been a change in Resolution Bandwidth, Span, or Alignment since the previous Tracking Peak.**

**The message does not apply to the E4401B or E4411B Spectrum Analyzer.**

**Informational** WARNING: You are about to delete all of the contents on directory "x:\xxxxx\". Press Delete Now again to proceed or any other key to abort.

**If you select a directory or subdirectory to delete, this popup message is displayed when you press Delete Now. ("x:\xxxxx\" in the message is the full path and directory name).**

**Informational** Volume <name> formatted

**The indicated disk has been successfully formatted.**

## Annunciator Bar Messages

Annunciator    Align

This message appears in the left side of the annunciator bar in red. When this message appears it indicates that there is one or more condition that has affected the alignment. For the possible conditions and suggested resolutions, refer to [Align Now All Needed \(Align Needed\) on page 58](#), [Align Now RF Needed \(Align Now RF Needed\) on page 59](#), [Align RF Skipped \(Align RF Skipped\) on page 59](#), and [System Alignments, Align Now, All Required on page 63](#).

Annunciator    Ext Ref

This message appears in the right side of the annunciator bar in green. When this message appears it indicates that there is one or more condition that affects the reference source. For the possible conditions and suggested resolutions, refer to [Ext Ref on page 60](#).

Annunciator    FreqRefUnlock

This message appears in the left side of the annunciator bar in red. When this message appears it indicates that there is one or more condition that results in a frequency reference error. For the possible conditions and suggested resolutions, refer to [Frequency Reference Error on page 60](#).

Annunciator    Overload

This message appears in the left side of the annunciator bar in red. When this message appears it indicates that there is one or more condition that causes a system overload. For the possible conditions and suggested resolutions, refer to [IF Overload on page 61](#) and [Overload on page 62](#).

**Annunciator**    Uncal

This message appears in the left side of the annunciator bar in red. When this message appears it indicates that there is one or more condition that results in uncalibrated results. For the possible conditions and suggested resolutions, refer to [Meas Uncal on page 62](#).

**Annunciator**    Unlevel

This message appears in the left side of the annunciator bar in red. When this message appears it indicates that there is one or more condition that affects the leveling of an internal signal, such as the local oscillator (LO) or the tracking generator (source). For the possible conditions and suggested resolutions, refer to [50 MHz Osc Unlevel on page 58](#), [LO Out Unlevel on page 61](#), [Source LO Unlevel on page 63](#), and [Source Unlevel on page 63](#).

**Annunciator**    Unlock

This message appears in the left side of the annunciator bar in red. When this message appears it indicates that there is one or more condition that affects locking one or more of the local oscillators (LOs). For the possible conditions and suggested resolutions, refer to [LO Unlock on page 62](#).





---

## **2** **Functional Testing**

## **What You Will Find in This Chapter**

This chapter describes the functional tests and provides information on how to perform them.

### **What Are the Functional Tests?**

Functional tests are tests of various instrument parameters that give a high degree of confidence that the analyzer is operating correctly. They are recommended as a check of analyzer operation for incoming inspection or after a repair. Measurement uncertainty analysis is not available for functional tests, and the analyzer is checked against limits that are wider than the published specifications. The functional tests are designed to test an analyzer operating within the temperature range defined by the analyzer specifications using a minimum set of test equipment. If a test does not pass, performance tests must be run to confirm a problem exists.

### **Functional Test Versus Performance Verification**

Performance verification tests check a wide range of analyzer parameters and provide the highest level of confidence that the analyzer is operating satisfactorily. They are used to verify that the analyzer conforms to published specifications. They are time consuming and require extensive test equipment. The functional tests check a much smaller range of parameters and a limited number of data points for each parameter. They require only limited test equipment.

## Test Descriptions

Each of the following test descriptions include the test limits (pass/fail criteria), a description of what the test does or what it measures, a list of equipment required for the performance of the test, an illustration of the test setup used, and a step by step test procedure. The tests are designed to be run on an analyzer operating within the operational temperature range defined by the analyzer specifications. Only perform tests after the specified warm-up time.

At the end of each test is a test results worksheet. Copy a worksheet to record your test results for each procedure you'll be conducting.

[Table 2-1 on page 76](#) includes a complete list of test equipment for all procedures in this chapter.

The tests included in this chapter are as follows:

Displayed Average Noise Level	<a href="#">page 78</a>
Frequency Readout Accuracy	<a href="#">page 96</a>
Marker Count Accuracy	<a href="#">page 99</a>
Frequency Response	<a href="#">page 100</a>
Reference Level Accuracy	<a href="#">page 105</a>
Resolution Bandwidth Switching Uncertainty	<a href="#">page 110</a>
Scale Fidelity	<a href="#">page 113</a>
Second Harmonic Spurious Responses	<a href="#">page 116</a>
Tracking Generator Level Flatness ( <i>E4401B and E4411B</i> )	<a href="#">page 119</a>
Tracking Generator Level Flatness ( <i>E4402B, E4403B, E4404B, E4405B, E4407B, E4408B</i> )	<a href="#">page 122</a>

**Table 2-1**

Test Equipment for All Procedures in Chapter 3:	Specifications:	Recommended Model:
<b>Signal Sources</b>		
Synthesized Sweeper	10 MHz-to maximum specified frequency of analyzer. Ext Ref Input	8340A/B or 836XX series
<b>Adapters</b>		
Type-N (m), to APC 3.5 (m)		1250-1743
Type-N (m) to BNC (f)		1250-0780
Type-N (f), to APC 3.5 (f)		1250-1745
Termination, 50 $\Omega$ Type-N (m)		908A
(2) Type-N (m), to APC 3.5 (f)		1250-1476
3.5 mm (m) to 3.5 mm (m)		5061-5311
SMA (f) to BNC (m)		1250-2015
<b>Cables</b>		
(2) BNC, 122-cm (48-in)		10503A
APC 3.5 mm		11500D
Type-N, 152-cm (60-in)		11500D
BNC, 9 inch		10502A
BNC, 122-cm (48-in)		10503A
APC 3.5 mm	E4407B and E4408B only	11500E
<b>Meters</b>		
Power Meter		438A or E4418A, E4419A
RF Power Sensor	100 kHz to 3.0 GHz	8482A
Microwave Power Sensor	50 MHz to 26.5GHz	8485A
<b>Miscellaneous</b>		
Power Splitter	E4401B, E4402B, E4403B, E4404B, E4405B and E4411B only	11667A

**Table 2-1**

Power Splitter	E4407B and E4408B only	11667B
50 MHz Low pass filter	Rejection at 80 MHz: >60 dB	0955-0306

## Displayed Average Noise Level

### Test Limits

Frequency Range	Model (50 $\Omega$ Input)	Maximum (50 $\Omega$ Input)	TR Entry
10 MHz to 500 MHz	E4401B, E4411B	- 119 dBm	1
501 MHz to 1.0 GHz	E4401B, E4411B	- 117 dBm	2
1.01 GHz to 1.5 GHz	E4401B	- 114 dBm	3
	E4411B	- 113 dBm	3
10 MHz to 1.0 GHz	E4402B, E4403B	- 117 dBm	4
	E4404B, E4405B, E4407B, E4408B	- 116 dBm	5
1.01 GHz to 2.0 GHz	E4402B, E4403B	- 116 dBm	6
	E4404B, E4405B, E4407B	- 116 dBm	7
	E4408B	- 115 dBm	8
2.01 GHz to 3.0 GHz	E4402B, E4403B	- 114 dBm	9
	E4404B, E4405B, E4407B, E4408B	- 112 dBm	10
3.01 GHz to 6.0 GHz	E4404B, E4405B, E4407B, E4408B	- 112 dBm	11
6.01 GHz to 6.7 GHz	E4404B	- 111 dBm	12
6.01 GHz to 12.0 GHz	E4405B, E4407B	- 111 dBm	13
	E4408B	- 110 dBm	14
12.01 GHz to 13.2 GHz	E4405B	- 107 dBm	15
12.01 GHz to 22 GHz	E4407B, E4408B	- 107 dBm	16
22.01 GHz to 26.5 GHz	E4407B	- 106 dBm	17
	E4408B	- 101 dBm	18

Frequency Range	Model (75 $\Omega$ Input)	Maximum (75 $\Omega$ Input)	TR Entry
10 MHz to 500 MHz	E4401B	- 66 dBmV	19
10 MHz to 500 MHz	E4411B	- 65 dBmV	20
501 MHz to 1.0 GHz	E4401B, E4411B	- 60 dBmV	21
1.01 GHz to 1.5 GHz	E4401B	- 56 dBmV	22

Frequency Range	Model (75 $\Omega$ Input)	Maximum (75 $\Omega$ Input)	TR Entry
1.01 GHz to 1.5 GHz	E4411B	- 53 dBmV	23

## Test Description

The Displayed Average Noise Level is measured within the frequency range specified. The analyzer input is terminated in either 50  $\Omega$  or 75  $\Omega$ , depending on analyzer options.

The test tunes the analyzer frequency across the band, uses the marker to locate the frequency with the highest response, and then reads the average noise in zero span.

## Required Equipment

Instrument	Critical Specifications (for this test)	Recommended HP/Agilent Model
<b>Adapters</b>		
Termination, 50 $\Omega$ Type-N (m)		908A
<b>Additional Equipment for 75 <math>\Omega</math> Input</b>		
Termination, 75 $\Omega$ Type-N (m)		909E
Adapter, Type-N (f), to BNC (m), 75 $\Omega$		1250-1534

**Figure 2-1** Equipment Setup

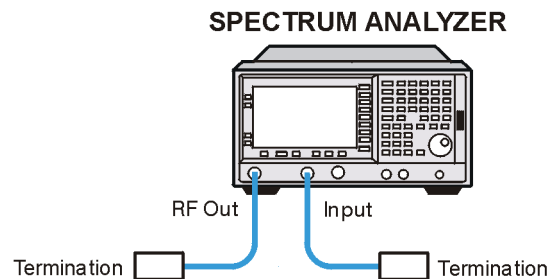

w1719a

## Procedure (10 MHz to 500 MHz) *E4401B* and *E4411B*

1. Connect the equipment as shown in [Figure 2-1](#).
2. Press **System, Power On/Preset, Preset Type (Factory), Preset** on the analyzer. Wait for the preset routine to finish. Set the analyzer by pressing the following keys:
  - FREQUENCY, Start Freq, 10, MHz**
  - Stop Freq, 500, MHz**
  - AMPLITUDE, -70, dBm (50  $\Omega$  Input only)**
  - AMPLITUDE, More, Y Axis Units, dBmV (75  $\Omega$  Input only)**
  - AMPLITUDE, Ref Level, -21.24, dBmV (75  $\Omega$  Input only)**
  - BW/Avg, Res BW, 1, MHz**
  - Video BW, 10, kHz**
3. Press the following keys on the analyzer:
  - Single**
  - BW/Avg, Average (On), 3, Enter**
  - Single**Wait until **AVG 3** is displayed to the left of the graticule (the analyzer will take 3 sweeps, then stop).
4. Press **Peak Search**. Record the marker frequency next to your analyzer model in the Measured Frequency column as entry (a) or (b) in [Table 2-2 on page 95](#) for 10 MHz to 500 MHz.
5. Press the following keys on the analyzer:
  - Sweep, Sweep (Cont)**
  - BW/Avg, Average (Off)**
  - BW/Avg, Res BW (Auto)**
  - Video BW (Auto)**
  - SPAN, 50, kHz**
  - FREQUENCY**
6. Press **Center Freq**, and set the center frequency of the analyzer to the frequency recorded in the Measured Frequency column as entry (a) or (b) of [Table 2-2](#) for 10 MHz to 500 MHz.



7. Press the following keys on the analyzer:  
**BW/Avg, Res BW, 1, kHz**  
**Video BW, 30, Hz**  
**Single**  
Wait for the sweep to finish.
8. Press the following keys on the analyzer:  
**Display, Display Line (On)**  
Adjust the display so that it is centered on the average trace noise, ignoring any residual responses.
9. Record the display line amplitude setting as TR Entry 1 (TR Entry 19 or 20 for a 75  $\Omega$  Input) in [Table 2-2 on page 95](#). The Average Noise Level should be less than the Maximum for the appropriate input impedance.

### **Procedure (501 MHz to 1.0 GHz) *E4401B and E4411B***

1. Press the following keys on the analyzer:  
**Sweep, Sweep (Cont)**  
**FREQUENCY, Start Freq, 501, MHz**  
**Stop Freq, 1.0, GHz**  
**BW/Avg, Res BW, 1, MHz**  
**Video BW, 10, kHz**
2. Press the following keys on the analyzer:  
**Single**  
**BW/Avg, Average (On), 3, Enter**  
**Single**  
Wait until **AVG 3** is displayed to the left of the graticule (the analyzer will take 3 sweeps, then stop).
3. Press **Peak Search**, and record the marker frequency next to your analyzer model in the Measured Frequency column as entry (c) in [Table 2-2 on page 95](#) for 501 MHz to 1.0 GHz.
4. Press the following keys on the analyzer:  
**Sweep, Sweep (Cont)**  
**BW/Avg, Average (Off)**  
**BW/Avg, Res BW (Auto)**

**Video BW (Auto)**

**SPAN, 50, kHz**

**FREQUENCY**

5. Press **Center Freq.** Set the center frequency of the analyzer to the frequency recorded in the Measured Frequency column as entry (c) in [Table 2-2 on page 95](#) for 501 MHz to 1.0 GHz.

6. Press the following keys on the analyzer:

**BW/Avg, Res BW, 1, kHz**

**Video BW, 30, Hz**

**Single**

Wait for the sweep to finish.

7. Press the following keys on the analyzer:

**Display, Display Line (On)**

Adjust the display line so that it is centered on the average trace noise, ignoring any residual responses.

8. Record the display line amplitude setting as TR Entry 2 (TR Entry 21 for a 75  $\Omega$  Input) in [Table 2-2 on page 95](#). The Average Noise Level should be less than the Maximum for the appropriate input impedance.

### **Procedure (1.01 GHz to 1.5 GHz) *E4401B* and *E4411B***

1. Press the following keys on the analyzer:

**Sweep, Sweep (Cont)**

**FREQUENCY, Start Freq, 1.0 GHz**

**Stop Freq, 1.5 GHz**

**BW/Avg, Res BW, 1, MHz**

**Video BW, 10, kHz**

2. Press the following keys on the analyzer:

**Single**

**BW/Avg, Average (On), 3, Enter**

**Single**

Wait until **AVG 3** is displayed to the left of the graticule (the analyzer will take 3 sweeps, then stop).

3. Press **Peak Search**, and record the marker frequency next to your analyzer model in the Measured Frequency column as entry (d) or (e) in [Table 2-2](#) for 1.01 GHz to 1.5 GHz.
4. Press the following keys on the analyzer:
  - Sweep, Sweep (Cont)**
  - BW/Avg, Average (Off)**
  - BW/Avg, Res BW (Auto)**
  - Video BW (Auto)**
  - SPAN, 50, kHz**
  - FREQUENCY**
5. Press **Center Freq**. Set the center frequency of the analyzer to the frequency recorded in the Measured Frequency column as entry (d) or (e) in [Table 2-2](#) for 1.01 GHz to 1.5 GHz.
6. Press the following keys on the analyzer:
  - BW/Avg, Res BW, 1, kHz**
  - Video BW, 30, Hz**
  - Single**Wait for the sweep to finish.
7. Press the following keys on the analyzer:
  - Display, Display Line (On)**Adjust the display line so that it is centered on the average trace noise, ignoring any residual responses.
8. Record the display line amplitude setting as TR Entry 3 (TR Entry 22 or 23 for a 75  $\Omega$  Input) in [Table 2-2](#). The average noise level should be less than the Maximum for the appropriate input impedance.

**Procedure (10 MHz to 1 GHz) *E4402B, E4403B, E4404B, E4405B, E4407B, and E4408B***

1. Press **System, Power On/Preset, Preset Type (Factory), Preset** on the analyzer. Wait for the preset routine to finish. Set the analyzer by pressing the following keys:
  - FREQUENCY, Start Freq, 10, MHz**
  - Stop Freq, 1.0, GHz**
  - AMPLITUDE, -70, dBm**
  - Attenuation (Man), 0, dB**

**BW/Avg, Res BW, 1, MHz**

**Video BW, 10, kHz**

2. Press the following keys on the analyzer:

**Single**

**BW/Avg, Average (On), 3, Enter**

**Single**

Wait until **AVG 3** is displayed to the left of the graticule (the analyzer will take three sweeps, then stop).

3. Press **Peak Search**. Record the marker frequency next to your analyzer model in the Measured Frequency column as entry (f) or (g) in [Table 2-2](#) for 10 MHz to 1.0 GHz.

4. Press the following keys on the analyzer:

**Sweep, Sweep (Cont)**

**BW/Avg, Average (Off)**

**BW/Avg, Res BW (Auto)**

**Video BW (Auto)**

**SPAN, 50, kHz**

**FREQUENCY**

5. Press **Center Freq**. Set the center frequency of the analyzer to the frequency recorded in the Measured Frequency column as entry (f) or (g) in [Table 2-2](#) for 10 MHz to 1.0 GHz.

6. Press the following keys on the analyzer:

**BW/Avg, Res BW, 1, kHz**

**Video BW, 30, Hz**

**Single**

Wait for the sweep to finish.

7. Press the following keys on the analyzer:

**Display, Display Line (On)**

Adjust the display line so that it is centered on the average trace noise, ignoring any residual responses.

8. If the analyzer is an E4402B or E4403B, record the display line amplitude setting as TR Entry 4 in [Table 2-2](#). Otherwise, record the display line amplitude setting as TR Entry 5 in [Table 2-2](#). The average noise level should be less than the Maximum.

**Procedure (1.01 GHz to 2 GHz) E4402B, E4403B, E4404B, E4405B, E4407B, and E4408B**

1. Press **System, Power On/Preset, Preset Type (Factory), Preset** on the analyzer. Wait for the preset routine to finish. Set the analyzer by pressing the following keys:

**FREQUENCY, Start Freq, 1.01, GHz**

**Stop Freq, 2, GHz**

**AMPLITUDE, -70, dBm**

**Attenuation (Man), 0, dB**

**BW/Avg, Res BW, 1, MHz**

**Video BW, 10, kHz**

2. Press the following keys on the analyzer:

**Single**

**BW/Avg, Average (On), 3, Enter**

**Single**

Wait until **AVG 3** is displayed to the left of the graticule (the analyzer will take 3 sweeps and then stop).

3. Press **Peak Search**. Record the marker frequency next to your analyzer model in the Measured Frequency column as entry (h), (i) or (j) in [Table 2-2](#) for 1.01 GHz to 2 GHz.

4. Press the following keys on the analyzer:

**Sweep, Sweep (Cont)**

**BW/Avg, Average (Off)**

**BW/Avg, Res BW (Auto)**

**Video BW (Auto)**

**SPAN, 50, kHz**

**FREQUENCY**

5. Press **Center Freq**. Set the center frequency of the analyzer to the frequency recorded in the Measured Frequency column as entry (h), (i) or (j) in [Table 2-2](#) for 1.01 GHz to 2 GHz.

6. Press the following keys on the analyzer:

**BW/Avg, Res BW, 1, kHz**

**Video BW, 30, Hz**

**Single**

Wait for the sweep to finish.

7. Press the following keys on the analyzer:

**Display, Display Line (On)**

Adjust the display line so that it is centered on the average trace noise, ignoring any residual responses.

8. If the analyzer is an E4402B or E4403B, record the display line amplitude setting as TR Entry 6 in [Table 2-2](#). Otherwise, record the display line amplitude setting as TR Entry 7 or 8 in [Table 2-2](#). The average noise level should be less than the Maximum.

### **Procedure (2.01 GHz to 3.0 GHz) E4402B, E4403B, E4404B, E4405B, E4407B, and E4408B**

1. Press **System, Power On/Presets, Preset Type (Factory), Preset** on the analyzer. Wait for the preset routine to finish. Set the analyzer by pressing the following keys:

**FREQUENCY, Start Freq, 2.01, GHz**

**Stop Freq, 3.0, GHz**

**AMPLITUDE, -70, dBm**

**Attenuation (Man), 0, dB**

**BW/Avg, Res BW, 1, MHz**

**Video BW, 10, kHz**

2. Press the following keys on the analyzer:

**Single**

**BW/Avg, Average (On), 3, Enter**

**Single**

Wait until **AVG 3** is displayed to the left of the graticule (the analyzer will take 3 sweeps and then stop).

3. Press **Peak Search**. Record the marker frequency next to your analyzer model in the Measured Frequency column as entry (k) or (l) in [Table 2-2](#) for 2.01 GHz to 3.0 GHz.

4. Press the following keys on the analyzer:

**Sweep, Sweep (Cont)**

**BW/Avg, Average (Off)**

**BW/Avg, Res BW (Auto)**

**Video BW (Auto)**

**SPAN, 50, kHz**

## FREQUENCY

5. Press **Center Freq.** Set the center frequency of the analyzer to the frequency recorded in the Measured Frequency column as entry (k) or (l) in [Table 2-2](#) for 2.01 GHz to 3.0 GHz.
6. Press the following keys on the analyzer:  
**BW/Avg, Res BW, 1, kHz**  
**Video BW, 30, Hz**  
**Single**  
Wait for the sweep to finish.
7. Press the following keys on the analyzer:  
**Display, Display Line (On)**  
Adjust the display line so that it is centered on the average trace noise, ignoring any residual responses.
8. If the analyzer is an E4402B or E4403B, record the display line amplitude setting as TR Entry 9 in [Table 2-2](#). Otherwise, record the display line amplitude setting as TR Entry 10 in [Table 2-2](#). The Average Noise Level should be less than the maximum.

## **Procedure (3.01 GHz to 6.0 GHz) *E4404B, E4405B, E4407B, and E4408B***

1. Press **System, Power On/Preset, Preset Type (Factory), Preset** on the analyzer. Wait for the preset routine to finish. Set the analyzer by pressing the following keys:  
**FREQUENCY, Start Freq, 3.01, GHz**  
**Stop Freq, 6.0. GHz**  
**AMPLITUDE, -70, dBm**  
**Attenuation (Man), 0, dB**  
**BW/Avg, Res BW, 1, MHz**  
**Video BW, 10, kHz**
2. Press the following keys on the analyzer:  
**Single**  
**BW/Avg, Average (On), 3, Enter**  
**Single**  
Wait until **AVG 3** is displayed to the left of the graticule (the analyzer will take 3 sweeps and then stop).

3. Press **Peak Search**. Record the marker frequency next to your analyzer model in the Measured Frequency column as entry (m) in [Table 2-2](#) for 3.01 GHz to 6.0 GHz.
4. Press the following keys on the analyzer:
  - Sweep, Sweep (Cont)**
  - BW/Avg, Average (Off)**
  - BW/Avg, Res BW (Auto)**
  - Video BW (Auto)**
  - SPAN, 50, kHz**
  - FREQUENCY**
5. Press **Center Freq**. Set the center frequency of the analyzer to the frequency recorded in the Measured Frequency column as entry (m) in [Table 2-2](#) for 3.01 GHz to 6.0 GHz.
6. Press the following keys on the analyzer:
  - BW/Avg, Res BW, 1, kHz**
  - Video BW, 30, Hz**
  - Single**Wait for the sweep to finish.
7. Press the following keys on the analyzer:
  - Display, Display Line (On)**Adjust the display line so that it is centered on the average trace noise, ignoring any residual responses.
8. Record the display line amplitude setting as TR Entry 11 in [Table 2-2](#). The Average Noise Level should be less than the Maximum.

### **Procedure (6.01 GHz to 6.7 GHz) E4404B**

1. Press **System, Power On/Preset, Preset Type (Factory), Preset** on the analyzer. Wait for the preset routine to finish. Set the analyzer by pressing the following keys:
  - FREQUENCY, Start Freq, 6.01, GHz**
  - Stop Freq, 6.7, GHz**
  - AMPLITUDE, -70, dBm**
  - Attenuation (Man), 0, dB**
  - BW/Avg, Res BW, 1, MHz**



**Video BW, 10, kHz**

2. Press the following keys on the analyzer:

**Single**

**BW/Avg, Average (On), 3, Enter**

**Single**

Wait until **AVG 3** is displayed to the left of the graticule (the analyzer will take 3 sweeps and then stop).

3. Press **Peak Search**. Record the marker frequency next to your analyzer model in the Measured Frequency column as entry (n) in [Table 2-2](#) for 6.01 GHz to 6.7 GHz.

4. Press the following keys on the analyzer:

**Sweep, Sweep (Cont)**

**BW/Avg, Average (Off)**

**BW/Avg, Res BW (Auto)**

**Video BW (Auto)**

**SPAN, 50, kHz**

**FREQUENCY**

5. Press **Center Freq**. Set the center frequency of the analyzer to the frequency recorded in the Measured Frequency column as entry (n) in [Table 2-2](#) for 6.01 GHz to 6.7 GHz.

6. Press the following keys on the analyzer:

**BW/Avg, Res BW, 1, kHz**

**Video BW, 30, Hz**

**Single**

Wait for the sweep to finish.

7. Press the following keys on the analyzer:

**Display, Display Line (On)**

Adjust the display line so that it is centered on the average trace noise, ignoring any residual responses.

8. Record the display line amplitude setting as TR Entry 12 in [Table 2-2](#). The Average Noise Level should be less than the Maximum.

## **Procedure (6.01 GHz to 12.0 GHz) *E4405B, E4407B, and E4408B***

1. Press **System, Power On/Preset, Preset Type (Factory), Preset** on the analyzer. Wait for the preset routine to finish. Set the analyzer by pressing the following keys:

**FREQUENCY, Start Freq, 6.01, GHz**

**Stop Freq, 12.0, GHz**

**AMPLITUDE, -70, dBm**

**Attenuation (Man), 0, dB**

**BW/Avg, Res BW, 1, MHz**

**Video BW, 10, kHz**

2. Press the following keys on the analyzer:

**Single**

**BW/Avg, Average (On), 3, Enter**

**Single**

Wait until **AVG 3** is displayed to the left of the graticule (the analyzer will take 3 sweeps and then stop).

3. Press **Peak Search**. Record the marker frequency next to your analyzer model in the Measured Frequency column as entry (o) or (p) in [Table 2-2](#) for 6.01 GHz to 12.0 GHz.

4. Press the following keys on the analyzer:

**Sweep, Sweep (Cont)**

**BW/Avg, Average (Off)**

**BW/Avg, Res BW (Auto)**

**Video BW (Auto)**

**SPAN, 50, kHz**

**FREQUENCY**

5. Press **Center Freq**. Set the center frequency of the analyzer to the frequency recorded in the Measured Frequency column as entry (o) or (p) in [Table 2-2](#) for 6.01 GHz to 12.0 GHz.

6. Press the following keys on the analyzer:

**BW/Avg, Res BW, 1, kHz**

**Video BW, 30, Hz**

**Single**

Wait for the sweep to finish.

7. Press the following keys on the analyzer:

**Display, Display Line (On)**

Adjust the display line so that it is centered on the average trace noise, ignoring any residual responses.

8. Record the display line amplitude setting as TR Entry 13 or 14 in [Table 2-2](#). The average noise level should be less than the Maximum.

### **Procedure (12.01 GHz to 13.2 GHz) E4405B**

1. Press **Preset System, Power On/Presets, Preset Type (Factory), Preset**, on the analyzer. Wait for the preset routine to finish. Set the analyzer by pressing the following keys:

**FREQUENCY, Start Freq, 12.01, GHz**

**Stop Freq, 13.2, GHz**

**AMPLITUDE, -70, dBm**

**Attenuation (Man), 0, dB**

**BW/Avg, Res BW, 1, MHz**

**Video BW, 10, kHz**

2. Press the following keys on the analyzer:

**Single**

**BW/Avg, Average (On), 3, Enter**

**Single**

Wait until **AVG 3** is displayed to the left of the graticule (the analyzer will take 3 sweeps and then stop).

3. Press **Peak Search**. Record the marker frequency next to your analyzer model in the Measured Frequency column as entry (q) in [Table 2-2](#) for 12.01 GHz to 13.2 GHz.
4. Press the following keys on the analyzer:

**Sweep, Sweep (Cont)**

**BW/Avg, Average (Off)**

**BW/Avg, Res BW (Auto)**

**Video BW (Auto)**

**SPAN, 50, kHz**

**FREQUENCY**

5. Press **Center Freq**. Set the center frequency of the analyzer to the frequency recorded in the Measured Frequency column as entry (q) in [Table 2-2](#) for 12.01 GHz to 13.2 GHz.
6. Press the following keys on the analyzer:  
**BW/Avg, Res BW, 1, kHz**  
**Video BW, 30, Hz**  
**Single**  
Wait for the sweep to finish.
7. Press the following keys on the analyzer:  
**Display, Display Line (On)**  
Adjust the display line so that it is centered on the average trace noise, ignoring any residual responses.
8. Record the display line amplitude setting as TR Entry 15 in [Table 2-2](#). The Average Noise Level should be less than the Maximum.

### **Procedure (12.01 GHz to 22 GHz) E4407B and E4408B**

1. Press **System, Power On/Preset, Preset Type (Factory), Preset** on the analyzer. Wait for the preset routine to finish. Set the analyzer by pressing the following keys:  
**FREQUENCY, Start Freq, 12.01, GHz**  
**Stop Freq, 22, GHz**  
**AMPLITUDE, -70, dBm**  
**Attenuation (Man), 0, dB**  
**BW/Avg, Res BW, 1, MHz**  
**Video BW, 10, kHz**
2. Press the following keys on the analyzer:  
**Single**  
**BW/Avg, Average (On), 3, Enter**  
**Single**  
Wait until **AVG 3** is displayed to the left of the graticule (the analyzer will take 3 sweeps and then stop).
3. Press **Peak Search**. Record the marker frequency next to your analyzer model in the Measured Frequency column as entry (r) in [Table 2-2](#) for 12.01 GHz to 22 GHz.

4. Press the following keys on the analyzer:
  - Sweep, Sweep (Cont)**
  - BW/Avg, Average (Off)**
  - BW/Avg, Res BW (Auto)**
  - Video BW (Auto)**
  - SPAN, 50, kHz**
  - FREQUENCY**
5. Press **Center Freq.** Set the center frequency of the analyzer to the frequency recorded in the Measured Frequency column as entry (r) in [Table 2-2](#) for 12.01 GHz to 22 GHz.
6. Press the following keys on the analyzer:
  - BW/Avg, Res BW, 1, kHz**
  - Video BW, 30, Hz**
  - Single**Wait for the sweep to finish.
7. Press the following keys on the analyzer:
  - Display, Display Line (On)**Adjust the display line so that it is centered on the average trace noise, ignoring any residual responses.
8. Record the display line amplitude setting as TR Entry 16 in [Table 2-2](#). The Average Noise Level should be less than the Maximum.

### **Procedure (22.01 GHz to 26.5 GHz) *E4407B* and *E4408B***

1. Press **System, Power On/Preset, Preset Type (Factory), Preset** on the analyzer. Wait for the preset routine to finish. Set the analyzer by pressing the following keys:
  - FREQUENCY, Start Freq, 22.01, GHz**
  - Stop Freq, 26.5, GHz**
  - AMPLITUDE, -70, dBm**
  - Attenuation (Man), 0, dB**
  - BW/Avg, Res BW, 1, MHz**
  - Video BW, 10, kHz**

2. Press the following keys on the analyzer:

**Single**

**BW/Avg, Average (On), 3, Enter**

**Single**

Wait until **AVG 3** is displayed to the left of the graticule (the analyzer will take 3 sweeps and then stop).

3. Press **Peak Search**. Record the marker frequency next to your analyzer model in the Measured Frequency column as entry (s) or (t) in [Table 2-2](#) for 22.01 GHz to 26.5 GHz.
4. Press the following keys on the analyzer:

**Sweep, Sweep (Cont)**

**BW/Avg, Average (Off)**

**BW/Avg, Res BW (Auto)**

**Video BW (Auto)**

**SPAN, 50, kHz**

**FREQUENCY**

5. Press **Center Freq**. Set the center frequency of the analyzer to the frequency recorded in the Measured Frequency column as entry (s) or (t) in [Table 2-2](#) for 22.01 GHz to 26.5 GHz.
6. Press the following keys on the analyzer:

**BW/Avg, Res BW, 1, kHz**

**Video BW, 30, Hz**

**Single**

Wait for the sweep to finish.

7. Press the following keys on the analyzer:

**Display, Display Line (On)**

Adjust the display line so that it is centered on the average trace noise, ignoring any residual responses.

8. Record the display line amplitude setting as TR Entry 17 or 18 in [Table 2-2](#). The Average Noise Level should be less than the Maximum.

**Table 2-2 Display Average Noise Level Worksheet**

Model Number	Frequency Range	Measured Frequency	Average Noise Level (TR Entry)	Maximum	
				50 $\Omega$ Input	75 $\Omega$ Input
E4401B	10 MHz to 500 MHz	(a) _____	(1) or (19) _____	- 119 dBm	- 66 dBmV
E4411B	10 MHz to 500 MHz	(b) _____	(1) or (20) _____	- 119 dBm	- 65 dBmV
E4401B, E4411B	501 MHz to 1.0 GHz	(c) _____	(2) or (21) _____	- 117 dBm	- 60 dBmV
E4401B	1.01 GHz to 1.5 GHz	(d) _____	(3) or (22) _____	- 114 dBm	- 56 dBmV
E4411B	1.01 GHz to 1.5 GHz	(e) _____	(3) or (23) _____	- 113 dBm	- 53 dBmV
E4402B, E4403B	10 MHz to 1.0 GHz	(f) _____	(4) _____	- 117 dBm	N/A
E4404B, E4405B, E4407B, E4408B	10 MHz to 1.0 GHz	(g) _____	(5) _____	- 116 dBm	N/A
E4402B, E4403B	1.01 GHz to 2.0 GHz	(h) _____	(6) _____	- 116 dBm	N/A
E4404B, E4405B, E4407B	1.01 GHz to 2.0 GHz	(i) _____	(7) _____	- 116 dBm	N/A
E4408B	1.01 GHz to 2.0 GHz	(j) _____	(8) _____	- 115 dBm	N/A
E4402B, E4403B	2.01 GHz to 3.0 GHz	(k) _____	(9) _____	- 114 dBm	N/A
E4404B, E4405B, E4407B, E4408B	2.01 GHz to 3.0 GHz	(l) _____	(10) _____	- 112 dBm	N/A
E4404B, E4405B, E4407B, E4408B	3.01 GHz to 6.0 GHz	(m) _____	(11) _____	- 112 dBm	N/A
E4404B	6.01 GHz to 6.7 GHz	(n) _____	(12) _____	- 111 dBm	N/A
E4405B, E4407B	6.01 GHz to 12.0 GHz	(o) _____	(13) _____	- 111 dBm	N/A
E4408B	6.01 GHz to 12.0 GHz	(p) _____	(14) _____	- 110 dBm	N/A
E4405B	12.01 GHz to 13.2 GHz	(q) _____	(15) _____	- 107 dBm	N/A
E4407B, E4408B	12.01 GHz to 22 GHz	(r) _____	(16) _____	- 107 dBm	N/A
E4407B	22.01 GHz to 26.5 GHz	(s) _____	(17) _____	- 106 dBm	N/A
E4408B	22.01 GHz to 26.5 GHz	(t) _____	(18) _____	- 101 dBm	N/A

## Frequency Readout Accuracy

### Test Limits

Span	Minimum	Maximum
10 MHz	1.48988 GHz	1.49012 GHz
100 kHz	1.4899988 GHz	1.4900012 GHz
Marker Count Accuracy with Counter Resolution at 1 Hz	1.489999999 GHz	1.490000001 GHz

### Test Description

The frequency readout accuracy of the analyzer is tested with an input signal of known frequency. Frequency reference error is eliminated by using the same frequency standard for the analyzer and the synthesized sweeper.

### Required Equipment

Instrument	Critical Specifications (for this test)	Recommended HP/Agilent Model
<b>Signal Sources</b>		
Synthesized Sweeper	10 MHz to 1.5 GHz External Reference Input	8340A/B or 836XX Series
<b>Adapters</b>		
Type-N (f), to APC 3.5(f)		1250-1745
<b>Cables</b>		
Type-N, 152-cm (60-in)		11500D
BNC, 122-cm (48-in)		10503A
<b>Additional Equipment for 75-Ohm Input</b>		
Pad, minimum loss		11852B
Type-N (f), to BNC (m), 75 $\Omega$		1250-1534



**Figure 2-2**

**Equipment Setup**

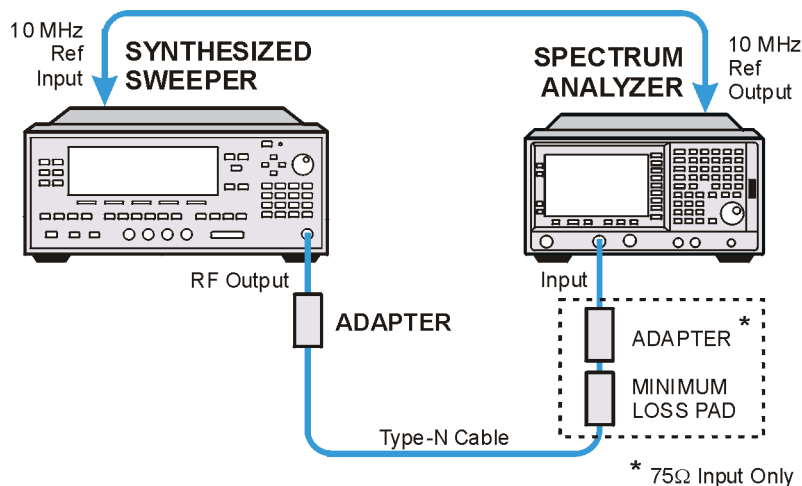

w171a

**Procedure**

1. Connect the equipment as shown in [Figure 2-2](#). Remember to connect the 10 MHz REF OUT of the analyzer to the 10 MHz REF IN of the synthesized sweeper.
2. Perform the following steps to set up the equipment:
  - a. Press **INSTRUMENT PRESET** on the synthesized sweeper, then set the controls as follows:
    - CW, 1.490, GHz**
    - POWER LEVEL, 10, - dBm**
  - b. Press **System, Power On/Preset, Preset Type (Factory), Preset** on the analyzer, then wait for the preset routine to finish. Set the analyzer by pressing the following keys:
    - Frequency, 1.490, GHz**
    - SPAN, 10, MHz**
    - BW/Avg, Res BW, 100, kHz**
    - Video BW, 30, kHz**

**CAUTION**

Use only 75 Ω cables, connectors, or adapters on analyzers with 75 Ω inputs, or damage to connectors will occur.

3. Press **Peak Search** on the analyzer to measure the frequency readout accuracy. Record this in the Marker Frequency Readout column in [Table 2-3 on page 99](#).
4. Press **Span, 100, kHz, BW/Avg, Res BW, 1, kHz, Video BW, 1, kHz**.

5. Press **Peak Search** on the analyzer to measure the frequency readout accuracy. Record this in the Marker Frequency Readout column in [Table 2-3 on page 99](#).

---

**NOTE** The Frequency Readout Accuracy is now complete. Continue with the Marker Count Accuracy functional check.

---

## Marker Count Accuracy

### Procedure

1. Press **System, Power On/Preset, Preset Type (Factory), Preset** on the analyzer, then wait for the preset routine to finish. Set the analyzer to measure the marker count accuracy by pressing the following keys:

**Frequency, 1.490, GHz**  
**SPAN, 10, MHz**  
**BW/Avg, Res BW, 100, kHz**  
**Freq Count, Resolution, 1, Hz**

2. Press **Peak Search**, then wait for a count to be taken (it may take several seconds).
3. Record the **Cntr1** frequency as the Marker Frequency Readout in [Table 2-3](#).

**Table 2-3**

**Frequency Readout and Marker Count Accuracy Worksheet**

<b>Span</b>	<b>Minimum</b>	<b>Marker Frequency Readout</b>	<b>Maximum</b>
10 MHz	1.48988 GHz		1.49012 GHz
100 kHz	1.4899988 GHz		1.4900012 GHz
Marker Count Accuracy w/Counter Resolution at 1 Hz	1.489999999 GHz		1.490000001 GHz

## Frequency Response

### Test Limits

ESA Model	Frequency	Minimum (dB)	Maximum (dB)
E4411B & E4401B	9 kHz to 1.5 GHz	-1.5	1.5
E4402B & E4403B	9 kHz to 3 GHz	-1.5	1.5
E4404B	9 kHz to 3 GHz	-1.5	1.5
	3.01 GHz to 6.7 GHz	-3.0	3.0
E4405B	9 kHz to 3 GHz	-1.5	1.5
	3.01 GHz to 6.7 GHz	-3.0	3.0
	6.71 GHz to 13.2 GHz	-3.5	3.5
E4407B & E4408B	9 kHz to 3 GHz	-1.5	1.5
	3.01 GHz to 6.7 GHz	-3.0	3.0
	6.71 GHz to 13.2 GHz	-3.5	3.5
	13.21 GHz to 25 GHz	-4.0	4.0
	25 GHz to 26.5 GHz	-4.5	4.5

### Test Description

The output of the synthesized sweeper is fed through a power splitter to a power sensor and the analyzer. The synthesized sweeper's power level is adjusted at 50 MHz to place the displayed signal at the analyzer center horizontal graticule line. Measurements are made at various points depending on the model being tested. The signal source amplitude is measured with a power meter to eliminate errors due to source flatness. The power meter is zeroed and calibrated before starting the measurement.

### Required Equipment

Instrument	Critical Specifications (for this test)	Recommended HP/Agilent Model
<b>Signal Sources</b>		
Synthesized Sweeper		8340A/B or 836xx Series

Instrument	Critical Specifications (for this test)	Recommended HP/Agilent Model
<b>Adapters</b>		
Type-N (f) to BNC (f)		1250-1474
APC 3.5 (f) to APC 3.5 (f)		5061-5311
BNC (f) to SMA (m)		1250-1237
Type-N (m), to APC 3.5(m)		1250-1743
<b>Cables</b>		
(2) APC 3.5mm (36 in)	E4407B and E4408B only	8120-4921 or 11500E
BNC (m) both ends, (48 in)		10503A
<b>Additional Equipment for 75-Ohm Input</b>		
Pad, minimum loss		11852B
Type-N (f), to BNC (m)		1250-1534
<b>Miscellaneous</b>		
Power Meter		EPM-441A (E4418A)
Power Sensor, 75 $\Omega$		8483A
Power Sensor, 50 $\Omega$		8485A
Power Splitter		11667B

**Figure 2-3 Equipment Setup**

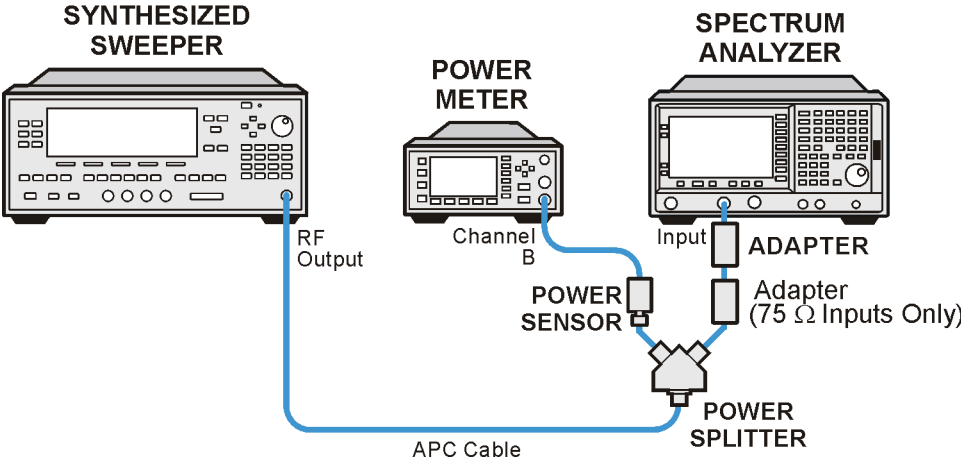

pl781b

## Procedure

1. Zero and calibrate the power meter and power sensor as described in the power meter operation manual.
2. Connect the equipment as shown in [Figure 2-3](#).

---

**CAUTION**

---

Use only 75  $\Omega$  cables, connectors, or adapters on analyzers with 75  $\Omega$  connectors, or damage to the connectors will occur.

3. Set the synthesized sweeper controls as follows:

**FREQUENCY, Center Freq, 50, MHz**

**POWER LEVEL, -8, dBm**

4. Press **System, Power On/Preset, Preset Type (Factory), Preset** on the analyzer and wait for the preset routine to finish. Set the analyzer by pressing the following keys.

**FREQUENCY, 50, MHz**

**CF Step, 50, MHz**

**SPAN, 20, kHz**

**AMPLITUDE, More, Y Axis Units, dBm**

**AMPLITUDE, -10, dBm**

**AMPLITUDE, Attenuation, 10, dB**

**Scale/Div, 2, dB**

**BW/Avg, Res BW, 10, kHz**

**Video BW, 3, kHz**

**Peak Search**

**FREQUENCY, Signal Track (On)**

5. Adjust the synthesized sweeper power level for a marker amplitude reading of -14 dBm +/- 0.10 dB.

---

**NOTE**

---

The power level of the synthesized sweeper remains unchanged for the duration of the test. For each new test frequency, the power sensor cal factor should be entered to minimize measurement errors.

6. Refer to [Table 2-4, "Frequency Response Worksheet."](#) Enter the marker readout amplitude for 50 MHz as displayed on the analyzer in the Analyzer Amplitude column.
7. Enter the power meter reading in the Power Meter Amplitude column.
8. Compute the flatness error at 50 MHz using the following equation and record the results in the Flatness Error column:  
$$\text{Flatness Error} = \text{Analyzer Amplitude} - \text{Power Meter Amplitude}$$
9. Perform the following steps for each center frequency setting listed in [Table 2-4](#).

- a. Tune the source to the next frequency listed in the Center Frequency column.
- b. Enter the power sensor cal factor for the new test frequency.
- c. Tune the analyzer center frequency by pressing the  $\uparrow$  key or press **FREQUENCY, Center Freq, “n”, and MHz** (where “n” is the next test frequency in [Table 2-4](#)).
- d. Press **Peak Search**.
- e. Enter the power meter reading in the Power Meter Amplitude column.
- f. Enter the analyzer reading in the Analyzer Amplitude column.
- g. Compute the flatness error using the following equation and record the results in the Flatness Error column:

$$\text{Flatness Error} = \text{Analyzer Amplitude} - \text{Power Meter Amplitude}$$

The flatness error should be less than the specified amount.

**Table 2-4 Frequency Response Worksheet**

<b>Model</b>	<b>Center Freq</b>	<b>Analyzer Amplitude</b>	<b>Power Meter Amplitude</b>	<b>Flatness Error</b>	<b>Flatness Error Test Limits (dB)</b>
All Models	50 MHz				± 1.5
	100 MHz				± 1.5
	750 MHz				± 1.5
	1250 MHz				± 1.5
	1500 MHz				± 1.5
E4402B – E4408B	2000 MHz				± 1.5
	2500 MHz				± 1.5
	2999 MHz				± 1.5
E4402B – E4408B	4250 MHz				± 3.0
	5750 MHz				± 3.0
	6699 MHz				± 3.0

**Table 2-4 Frequency Response Worksheet (Continued)**

<b>Model</b>	<b>Center Freq</b>	<b>Analyzer Amplitude</b>	<b>Power Meter Amplitude</b>	<b>Flatness Error</b>	<b>Flatness Error Test Limits (dB)</b>
E4402B – E4408B	8000 MHz				± 3.5
	9000 MHz				± 3.5
	10000 MHz				± 3.5
	11000 MHz				± 3.5
	13199 MHz				± 3.5
E4407B & E4408B	14000 MHz				± 4.0
	19000 MHz				± 4.0
	24000 MHz				± 4.0
	26500 MHz				± 4.5



## Reference Level Accuracy

### Test Limits

Reference Level		Minimum (dB)	Maximum (dB)
dBm	dBmV		
-30	21.76	Reference	Reference
-20	31.76	-1.40	1.40
-10	41.76	-1.40	1.40
-40	11.76	-1.40	1.40
-50	1.76	-1.40	1.40
-60	-8.24	-1.40	1.40
-70	-18.24	-2.0	2.0

### Test Description

A 50 MHz CW signal is applied to the Input of the analyzer. The amplitude of the source and the analyzer's reference level are decreased in 10 dB steps. The analyzer marker functions are used to measure the amplitude difference between steps. Reference Level Accuracy is tested in both Log and Linear Scale Modes. Most of the error is contributed from the output attenuator inaccuracy in the synthesized sweeper and not the analyzer.

### Required Equipment

Instrument	Critical Specifications (for this test)	Recommended HP/Agilent Model
<b>Signal Sources</b>		
Synthesized Sweeper	Output Level Accuracy 0 to -15 dBm: $\pm 1.0$ dB -16 dBm to -63 dBm: $\pm 1.4$ dB $\leq -64$ dBm: $\geq 2.0$ dB	8340A/B or 836XX Series
<b>Adapters</b>		
Type-N (m), to BNC f)		1250-1476
<b>Cables</b>		

Instrument	Critical Specifications (for this test)	Recommended HP/Agilent Model
Type-N, 152-cm (60-in)		11500D
BNC, 122-cm (48-in)		10503A
<b>Additional Equipment for 75-Ohm Input</b>		
Pad, minimum loss		11852B
Type-N (f), to BNC (m)		1250-1534

**Figure 2-4**

**Equipment Setup**

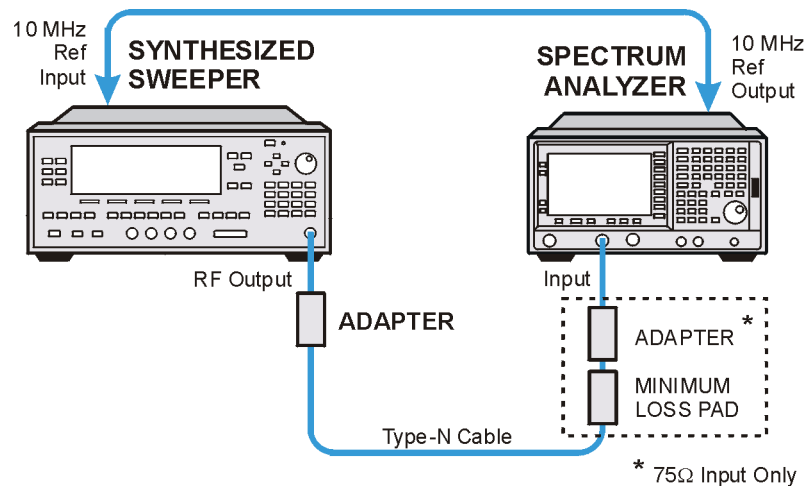

w171a

**Log Mode Procedure**

1. Connect the equipment as shown in [Figure 2-4](#).
2. Press **PRESET** on the synthesized sweeper. Set the synthesized sweeper controls as follows:
  - CW, 50, MHz**
  - Power Level, -30, dBm**
3. Press **System, Power On/Preset, Preset Type (Factory), Preset** on the analyzer, then wait for the preset routine to finish. Press **System, Alignments, Auto Align, Off**. Set the analyzer by pressing the following keys:
  - FREQUENCY, Center Freq, 50, MHz**
  - SPAN, 50, kHz**
  - AMPLITUDE, -30, dBm (50 Ω Input only)**
  - AMPLITUDE, More, Y Axis Units, dBmV (75 Ω Input only)**
  - AMPLITUDE, 21.76, dBmV (75 Ω Input only)**

Attenuation (Man), 5, dB  
BW/Avg, Res BW, 3, kHz  
Video BW, 30, Hz

4. Press **Peak Search** on the analyzer. Adjust the amplitude on the synthesized sweeper until the marker amplitude on the analyzer reads  $-30 \text{ dBm} \pm 0.10 \text{ dB}$ . Enter the synthesized sweeper power level as the Synthesized Sweeper Amplitude reference in [Table 2-5 on page 107](#).

NOTE

Under these analyzer conditions, the sweep time is 1.7 seconds. Therefore, the marker amplitude updates are fairly slow when adjusting the synthesizer output power.

5. Now that the reference has been established in step 4, adjust the synthesized sweeper power level and the analyzer reference level according to [Table 2-5 on page 107](#). (The synthesized sweeper output power and the analyzer's reference level will be changed in 10 dB steps.)
6. On the analyzer, press **Single**, wait for a sweep to finish, and then press **Peak Search, Marker, Delta**.
7. For each new synthesized sweeper power level and analyzer reference level change, press the following keys on the analyzer:

**Single**  
**Peak Search**  
Record the Analyzer Marker Amplitude reading in [Table 2-5](#).

**Table 2-5 Reference Level Accuracy Worksheet (Log Mode)**

Analyzer Reference Level		Synthesized Sweeper Amplitude (dBm)	Minimum (dB)	Analyzer Marker $\Delta$ Amplitude (dB)	Maximum (dB)
dBm	dBmV				
-30	21.76	Reference = _____	0 (Reference)	0 (Reference)	0 (Reference)
-20	31.76	Reference + (10 dB)	8.60		11.40
-10	41.76	Reference + (20 dB)	18.60		21.40
-40	11.76	Reference + (-10 dB)	-11.40		-8.60
-50	1.76	Reference + (-20 dB)	-21.40		-18.60
-60	- 8.24	Reference + (-30 dB)	-31.40		-28.60
-70	-18.24	Reference + (-40 dB)	-42.0		-38.0

## Linear Mode Procedure

1. Set the power level on the synthesized sweeper to  $-30$  dBm by pressing **Power Level,  $-30$ , dBm**.
2. Set the analyzer by pressing the following keys:
  - Sweep, Sweep (Cont)**
  - AMPLITUDE,  $-30$ , dBm (50  $\Omega$  Input)**
  - AMPLITUDE, More, Y Axis Units, dBmV (75  $\Omega$  Input)**
  - AMPLITUDE,  $+21.76$ , dBmV (75  $\Omega$  Input)**
  - Scale Type (Lin)**
  - Marker, Off**
3. Adjust the amplitude on the synthesized sweeper until the marker amplitude on the analyzer reads  $-30$  dBm  $\pm 0.10$  dB. Enter the synthesized sweeper power level as the Synthesized Sweeper Amplitude reference in [Table 2-6](#).

---

NOTE

Under these analyzer conditions, the sweep time is 1.7 seconds. Therefore, the marker amplitude updates are fairly slow when adjusting the synthesizer output power.

---

4. Now that the reference has been established in step 4, adjust the synthesized sweeper power level and the analyzer reference level according to [Table 2-6](#). (The synthesized sweeper output power and the analyzer's reference level will be changed in 10 dB steps.)
5. On the analyzer, press **Single**, wait for a sweep to finish, and then press **Peak Search, Marker, Delta**.
6. For each new synthesized sweeper power level and analyzer reference level change, press the following keys on the analyzer:

- Single**
- Peak Search**

Record the Analyzer Marker Amplitude reading in [Table 2-6](#).

**Table 2-6 Reference Level Accuracy Worksheet (Linear Mode)**

Analyzer Reference Level		Synthesized Sweeper Amplitude (dBm)	Minimum (dB)	Analyzer Marker $\Delta$ Amplitude (dB)	Maximum (dB)
dBm	dBmV				
-30	21.76	Reference = _____	0 (Reference)	0 (Reference)	0 (Reference)
-20	31.76	Reference + (10 dB)	8.60		11.40
-10	41.76	Reference + (20 dB)	18.60		21.40
-40	11.76	Reference + (-10 dB)	-11.40		-8.60
-50	1.76	Reference + (-20 dB)	-21.40		-18.60
-60	- 8.24	Reference + (-30 dB)	-31.40		-28.60
-70	-18.24	Reference + (-40 dB)	-42.0		-38.0

## Resolution Bandwidth Switching Uncertainty

### Test Limits

Resolution Bandwidth	Minimum (dB)	Maximum (dB)
1 kHz	0 (Ref)	0 (Ref)
3 kHz	-0.3 dB	0.3 dB
10 kHz	-0.3 dB	0.3 dB
30 kHz	-0.3 dB	0.3 dB
100 kHz	-0.3 dB	0.3 dB
300 kHz	-0.3 dB	0.3 dB
1 MHz	-0.3 dB	0.3 dB
3 MHz	-0.3 dB	0.3 dB
5 MHz	-0.6 dB	0.6 dB

### Test Description

To measure the resolution-bandwidth switching uncertainty, an amplitude reference is taken with the resolution bandwidth set to 1 kHz. The resolution bandwidth is changed to settings between 5 MHz and 3 kHz and the amplitude variation is measured at each setting using the marker delta function and compared to the specification. The span is changed as necessary to maintain approximately the same aspect ratio.

### Required Equipment

No equipment required for analyzer models E4401B and E4411B.

Instrument	Critical Specifications (for this test)	Recommended Model
<b>Cables</b>		
BNC, 9 inch		10502A
<b>Adapter</b>		
Type N to BNC		1250-0780 or 1250-1476

**Figure 2-5**      **Equipment Setup**

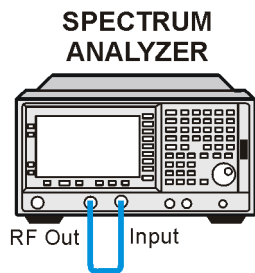

vI71b

## Procedure

---

### NOTE

The 50 MHz reference output will automatically be switched internally on the E4401B and E4411B and will not require any external connections. All other ESA analyzers require that the AMPTD REF OUT be connected to the INPUT to perform this test.

---

1. Press **System, Power On/Preset, Preset Type (Factory), Preset** on the analyzer. Wait for the preset routine to finish. Set the analyzer by pressing the following keys:
  - Input/Output, Amptd Ref (On)** (E4401B and E4411B)
  - Input/Output, Amptd Ref Out (On)** (E4402B, E4403B, E4404B, E4405B, E4407B, and E4408B).Connect a cable from the **AMPTD REF OUT** to the **INPUT 50  $\Omega$** , as shown in [Figure 2-5](#) (E4402B, E4403B, E4404B, E4405B, E4407B, and E4408B).
  - FREQUENCY, 50, MHz**
  - SPAN, 50, kHz**
  - AMPLITUDE, More, Y Axis Units, dBm** (75  $\Omega$  Input only)
  - AMPLITUDE, -20, dBm**
  - AMPLITUDE, Scale/Div, 1, dB**
  - BW/Avg, Res BW, 1, kHz**
  - Video BW, 1, kHz**
2. Press **AMPLITUDE** and use the knob to adjust the reference level until the signal appears five divisions (mid-screen) below the reference level. Press the following keys on the analyzer:
  - Peak Search**
  - Marker, Delta**
  - FREQUENCY, Signal Track (On)**
3. Set the analyzer Resolution Bandwidth and Span according to [Table 2-7 on page 112](#).

4. Press **Peak Search**, then record the  $\Delta$  Mkr 1 amplitude reading in [Table 2-7](#).
5. Repeat step 3 and 4 for each of the remaining resolution bandwidth and span settings listed in [Table 2-7](#). The  $\Delta$  Mkr 1 amplitude reading should be within the range indicated in the table “[Test Limits](#)” on [page 110](#).

**Table 2-7 Resolution Bandwidth Switching Uncertainty Worksheet**

<b>Resolution Bandwidth Setting</b>	<b>SPAN Setting</b>	<b><math>\Delta</math> Mkr 1 Amplitude Reading</b>
1 kHz	50 kHz	0 (Ref)
3 kHz	50 kHz	
10 kHz	50 kHz	
30 kHz	500 kHz	
100 kHz	500 kHz	
300 kHz	5 MHz	
1 MHz	10 MHz	
3 MHz	10 MHz	
5 MHz	50 MHz	



## Scale Fidelity

### Test Limits

dB from Reference Level	Minimum (dB)	Maximum (dB)
-4	-1.0	1.0
-16	-1.4	1.4
-28	-1.4	1.4
-40	-1.4	1.4
-52	-1.4	1.4
-64	-2.0	2.0

### Test Description

A 50 MHz CW signal is applied from a synthesized sweeper to the input of the analyzer. The source is adjusted for a response at the reference level. The synthesized sweeper amplitude is adjusted to achieve a nominal amplitude below the reference level. The analyzer's amplitude marker is compared to the actual source change to determine the scale fidelity error. Most of the error is the source's output attenuator inaccuracy from the synthesized sweeper.

### Required Equipment

Instrument	Critical Specifications (for this test)	Recommended HP/Agilent Model
<b>Signal Sources</b>		
Synthesized Sweeper	Output Level Accuracy 0 to -15 dBm: $\pm 1.0$ dB -16 dBm to -63 dBm: $\pm 1.4$ dB $\leq -64$ dBm: $\geq 2.0$ dB	8340A/B or 836XX Series
<b>Adapters</b>		
Type-N (m), to BNC (f)		1250-1476
<b>Cables</b>		
Type-N, 152-cm (60-in)		11500D
BNC, 122-cm (48-in)		10503A

Instrument	Critical Specifications (for this test)	Recommended HP/Agilent Model
<b>Additional Equipment for 75-Ohm Input</b>		
Pad, minimum loss		11852B
Type-N (f), to BNC (m)		1250-1534

**Figure 2-6**

**Equipment Setup**

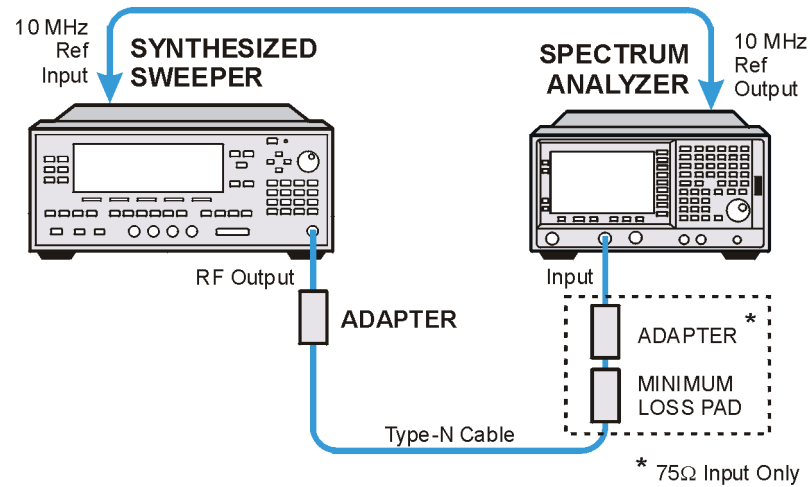

w171a

**Procedure**

1. Connect the equipment as shown in [Figure 2-6](#).
2. Preset the synthesized sweeper. Set the synthesized sweeper controls as follows:
  - CW, 50, MHz**
  - Power Level, 0, dBm (50 Ω Input)**
  - Power Level, 4, dBm (75 Ω Input)**
3. Press **System, Power On/Preset, Preset Type (Factory), Preset** on the analyzer, then wait for the preset routine to finish. Press **System, Alignments, Auto Align, Off**. Set the analyzer by pressing the following keys:
  - FREQUENCY, Center Freq, 50, MHz**
  - SPAN, 45, kHz**
  - AMPLITUDE, Attenuation, 10, dB**
  - BW/Avg, Res BW, 3, kHz**
  - Video BW, 1, kHz**
  - Peak Search**

- Adjust the amplitude on the synthesized sweeper until the marker amplitude on the analyzer reads 0 dBm +/- 0.10 dB. Record the synthesized sweeper output level as the reference in [Table 2-8 on page 115](#).

---

NOTE *75 Ω Input only.* Adjust the synthesized sweeper amplitude until the analyzer's marker reads 48.8 dBmV +/- 0.10 dB.

---

- On the analyzer, press the following keys:  
  - Single
  - Peak Search
  - Marker, Delta
- Record the marker delta reading in [Table 2-8](#). At each new synthesized sweeper power level, press **Single**, **Peak Search**, and record the marker amplitude level.

**Table 2-8**      **Scale Fidelity Worksheet**

Synthesized Sweeper Level	Minimum (dB)	Marker Level (dB)	Maximum (dB)
Reference=_____	0 (Reference)		0 (Reference)
Reference -4 dB	-5.0		-3.0
Reference -16 dB	-17.40		-15.60
Reference -28 dB	-29.40		-26.60
Reference -40 dB	-41.40		-38.60
Reference -52 dB	-53.40		-50.60
Reference -64 dB	-66.0		-62.0

## Second Harmonic Spurious Responses

### Test Limits

Model Number	Maximum
E4401B	-55 dBc
E4402B	-55 dBc
E4403B	-50 dBc
E4404B	-55 dBc
E4405B	-55 dBc
E4407B	-55 dBc
E4408B	-50 dBc
E4411B	-55 dBc

### Test Description

To test second harmonic distortion, a 50 MHz low pass filter is used to filter the source output, ensuring that harmonics read by the analyzer are internally generated and not coming from the source. The source power and input attenuation on the analyzer are adjusted so -20 dBm is the power level at the first mixer.

### Required Equipment

Table 2-9

Instrument	Critical Specifications (for this test)	Recommended HP/Agilent Model
<b>Signal Sources</b>		
Synthesized Sweeper		8340A/B or 836XX Series
<b>Miscellaneous</b>		
50 MHz Low pass filter	Rejection at 80 MHz: >60 dB	0955-0306
<b>Adapters</b>		
(2) Type-N (m) to BNC (f)		1250-1476
BNC (f) to BNC (f)		1250-0080

**Table 2-9**

Instrument	Critical Specifications (for this test)	Recommended HP/Agilent Model
Type-N (f), to APC 3.5(f)		1250-1745
<b>Cables</b>		
(2) BNC, 122-cm (48-in)		10503A
<b>Additional Equipment for 75 Ω Input</b>		
Pad, minimum loss		11852B
Type-N (f), to BNC (m)		1250-1534

**Figure 2-7 Equipment Setup**

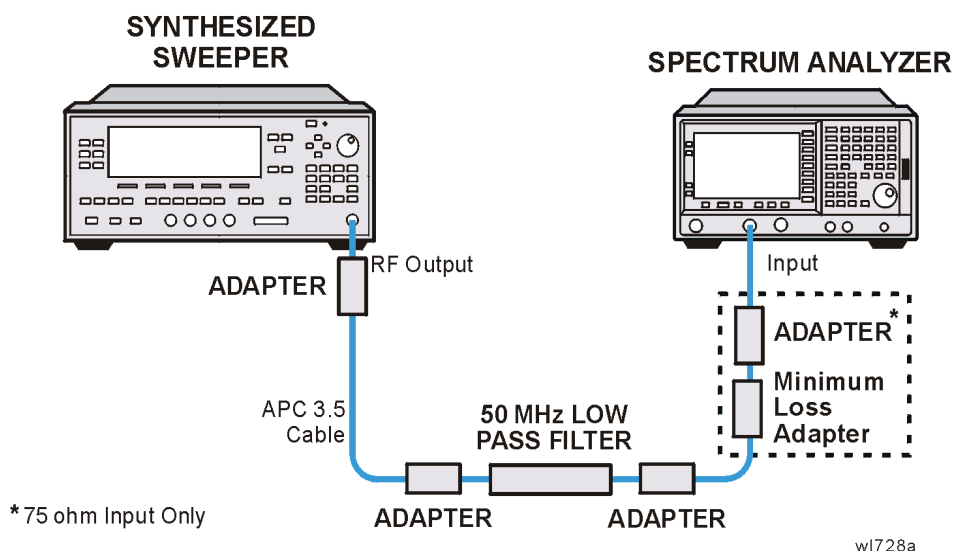

**Procedure**

1. Connect the equipment as shown in [Figure 2-7](#).
2. Set the synthesized sweeper controls as follows:

**Frequency, 40, MHz**  
**POWER LEVEL, -10, dBm (50 Ω Input only)**  
**POWER LEVEL, -4.3, dBm (75 Ω Input only)**

**NOTE** *75 Ω Input only.* Connect the minimum loss adapter between the low pass filter and 75 Ω Input.

3. Press **System, Power On/Preset, Preset Type (Factory), Preset** on the analyzer. Wait for the preset routine to finish.  
Set the analyzer by pressing the following keys:

**FREQUENCY, Center Freq, 40, MHz**  
**SPAN, 1, MHz**  
**AMPLITUDE, -10, dBm (50  $\Omega$  Input only)**  
**AMPLITUDE, 44, dBmV (75  $\Omega$  Input only)**  
**Attenuation (Man), 10, dB**  
**BW/Avg, Res BW, 30, kHz**

4. Adjust the synthesized sweeper power level to place the peak of the signal at the reference level.
5. Set the analyzer by pressing the following keys:

**SPAN, 50, kHz**  
**BW/Avg, Res BW, 1, kHz**  
**Video BW, 100, Hz**

6. Wait for two sweeps to finish, then press the following analyzer keys:

**Peak Search**  
**Mkr →**  
**Mkr → CF Step**  
**Marker, Delta**  
**FREQUENCY**

7. Press the  $\hat{\uparrow}$  key on the analyzer to step to the second harmonic (at 80 MHz). Press **Peak Search**. The marker delta amplitude reading should be less than the Maximum value listed in the Test Limits Table.

## Tracking Generator Level Flatness: Models E4401B and E4411B, Options 1DN and 1DQ

### Test Limits

	Minimum	Maximum
Flatness $\leq$ 10 MHz, 50 $\Omega$	-2.5 dB	2.5 dB
Flatness $>$ 10 MHz, 50 $\Omega$	-2.0 dB	2.0 dB
Flatness $>$ 10 MHz, 75 $\Omega$	-3.0 dB	3.0 dB
Flatness $>$ 10 MHz, 75 $\Omega$	-2.5 dB	2.5 dB

### Test Description

A calibrated power sensor is connected to the tracking generator output to measure the power level at 50 MHz. The power meter is set for REL mode so that future power level readings are in dB relative to the power level at 50 MHz. The tracking generator is then stepped to several frequencies throughout its range. The output power difference relative to the power level at 50 MHz is measured at each frequency and recorded. Analyzers with 75  $\Omega$  tracking generators are only tested from 1 MHz to 1500 MHz.

### Required Equipment

Instrument	Critical Specifications (for this test)	Recommended HP/Agilent Model
<b>Meters</b>		
Power Meter		438A or E4418A, E4419A
RF Power Sensor	Frequency Range: 100 kHz to 1.5GHz	8482A
<b>Cables</b>		
BNC, 122-cm (48-in) (2)		10503A
<b>Additional Equipment for 75 <math>\Omega</math> Input</b>		
75 $\Omega$ Power Sensor	Frequency Range: 1 MHz to 1.5GHz	8483A

Instrument	Critical Specifications (for this test)	Recommended HP/Agilent Model
Type-N (f) to BNC (m), 75 $\Omega$ Adapter		1250-1534

**Figure 2-8** Equipment Setup

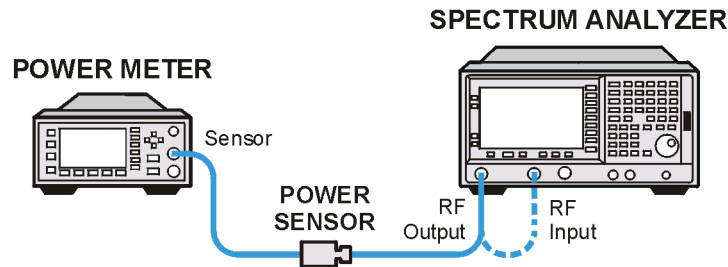

w712a

## Procedure

1. Calibrate the tracking generator by pressing **System, Alignments, Align Now, TG**. Connect the RF Out to the Input when prompted.
2. Press **System, Power On/Preset, Preset Type (Factory), Preset** on the analyzer, then wait for the preset routine to finish. Set the analyzer by pressing the following keys:
  - FREQUENCY, Center Freq, 50, MHz**
  - CF Step, 500, MHz**
  - SPAN, Zero Span**
  - Source, Amplitude (On), 0, dBm (50  $\Omega$  RF Output only)**
  - Source, Amplitude (On), +42.76, dBmV (75  $\Omega$  RF Output only)**
3. Zero and calibrate the power meter and RF power sensor. Make sure the power meter is reading out in dBm. Enter the power sensor 50 MHz cal factor into the power meter.

---

**NOTE** 75  $\Omega$  RF Out only: Zero and calibrate the 75  $\Omega$  power sensor.

4. Connect the power sensor to the RF Out on the analyzer as shown in [Figure 2-8](#).

---

**NOTE** 75  $\Omega$  RF Out only: Connect the 75  $\Omega$  power sensor through an adapter to the RF Out 75  $\Omega$ .

5. Press REL on the power meter. The power meter readout amplitudes are now relative to the power level at 50 MHz.



6. Set the analyzer center frequency to 100 kHz by pressing **FREQUENCY, 100, kHz**.

**NOTE**

*75  $\Omega$  RF Out only:* Set the analyzer center frequency to 1 MHz.

7. Enter the appropriate power sensor Cal Factor for the test frequency into the power meter as indicated on the label of the power sensor.
8. Record the power level displayed on the power meter as the Level Flatness in [Table 2-10](#).
9. Repeat steps 7 through 8 to measure the flatness at each center frequency setting listed in [Table 2-10](#). The  $\uparrow$  may be used to tune to center frequencies above 500 MHz.

**NOTE**

*75  $\Omega$  RF Out only:* Repeat steps 5 through 7 to measure the flatness at the frequencies above 1 MHz listed in [Table 2-10](#).

**Table 2-10****Tracking Generator Level Flatness Worksheet**

Center Frequency	Level Flatness (dB)
100 kHz or 1 MHz <sup>a</sup>	
5 MHz	
40 MHz	
50 MHz	0 (Ref)
80 MHz	
500 MHz	
1000 MHz	
1500 MHz	

- a. This frequency is 100 kHz for analyzers with 50  $\Omega$  tracking generators, and 1 MHz for analyzers with 75  $\Omega$  tracking generators.

## Tracking Generator Level Flatness: E4402B, E4403B, E4404B, E4405B, E4407B and E4408B, Option 1DN

### Test Limits

	Minimum	Maximum
Flatness $\leq$ 10 MHz	-3.5 dBm	+3.5 dBm
Flatness $>$ 10 MHz	-2.5 dBm	-2.5 dBm

### Test Description

A calibrated power sensor is connected to the tracking generator output to measure the power level at 50 MHz. The power meter is set for REL mode so that future power level readings are in dB relative to the power level at 50 MHz. The tracking generator is then stepped to several frequencies throughout its range. The output power difference relative to the power level at 50 MHz is measured at each frequency and recorded.

### Required Equipment

Table 2-11

Instrument	Critical Specifications (for this test)	Recommended HP/Agilent Model
<b>Meters</b>		
Power Meter		438A or E4418A, E4419A
RF Power Sensor	Frequency Range: 100 kHz to 3.0 GHz	8482A
<b>Adapters</b>		
Type-N (f) to BNC (m), 75-Ohm		1250-1534
<b>Cables</b>		
(2) BNC, 122-cm (48-in)		10503A

**Figure 2-9**      **Equipment Setup**

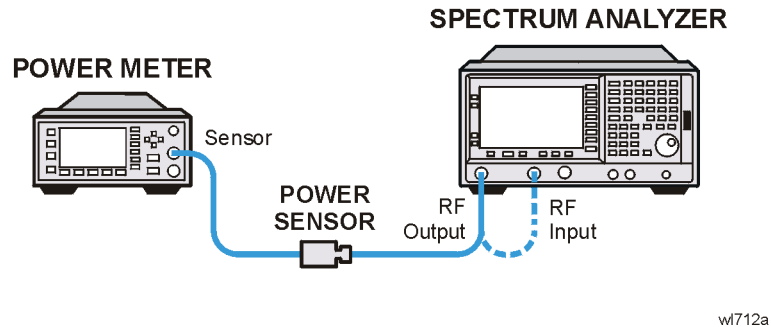

## Procedure

1. Calibrate the tracking generator by pressing **System, Alignments, Align Now, TG**. Connect the RF OUT to the RF INPUT when prompted.
2. Press **System, Power On/Preset, Preset Type (Factory), Preset** on the analyzer, then wait for the preset routine to finish. Set the analyzer by pressing the following keys:
  - FREQUENCY, Center Freq, 50, MHz**
  - CF Step, 100, MHz**
  - SPAN, Zero Span**
  - Source, Amplitude (On), -20, dBm**
  - System, Alignments, Auto Align, Off**
3. Zero and calibrate the power meter and power sensor. Make sure the power meter is reading out in dBm. Enter the power sensor 50 MHz cal factor into the power meter.
4. Connect the power sensor to the RF Out on the analyzer as shown in [Figure 2-9](#).
5. Press REL on the power meter. The power meter readout amplitudes are now relative to the power level at 50 MHz.
6. Set the analyzer center frequency to 100 kHz by pressing **FREQUENCY, 100, kHz**.
7. Enter the appropriate power sensor Cal Factor for the test frequency into the power meter as indicated on the label of the power sensor. This must be done at each test frequency.
8. Record the power level displayed on the power meter as the Level Flatness in [Table 2-12 on page 124](#).
9. Repeat steps 5 through 7 to measure the flatness at each center frequency setting listed in [Table 2-12](#). The  $\uparrow$  may be used to tune to center frequencies above 500 MHz.

10.Press System, Alignments, Auto Align, On.

**Table 2-12**

**Tracking Generator Level Flatness Worksheet**

Center Frequency	Level Flatness (dB)
100 kHz	
5 MHz	
40 MHz	
50 MHz	0 (Ref)
80 MHz	
500 MHz	
1000 MHz	
1500 MHz	
2000 MHz	
2300 MHz	
2500 MHz	
2700 MHz	
3.0 GHz	

---

# Index

---

## C

command error messages, [19](#), [22](#)

## D

device-specific error messages, [18](#)  
201 to 702, [19](#), [27](#)

## E

error messages

>10000, [19](#)

-199 to -100, [19](#), [22](#)

201 to 702, [19](#), [27](#)

-299 to -200, [18](#)

-399 to -300, [18](#)

-499 to -400, [18](#), [20](#), [21](#)

command, [19](#), [22](#)

device-specific, [18](#)

device-specific (201 to 702), [19](#),  
[27](#)

empty error queue, [20](#)

execution, [18](#)

format, [17](#)

GSM, [37](#)

measurement applications, [19](#)

query, [18](#), [20](#), [21](#)

types, [18](#)

error queues

empty message, [20](#)

front panel, [16](#)

SCPI remote interface, [17](#)

errors

-499 to -400, [21](#)

execution error messages, [18](#)

## F

flatness, [96](#)

frequency response, [96](#)

test description, [96](#)

frequency response, [96](#)

flatness, [96](#)

test description, [96](#)

front panel

error queue characteristics, [16](#)

functional test descriptions, [75](#)

functional testing

introduction, [74](#)

performance verification, [74](#)

test descriptions, [75](#)

test list, [75](#)

## M

measurement applications error  
messages, [19](#)

## Q

queries

error messages, [18](#), [20](#), [21](#)

## R

remote

interface (SCPI) error queue, [17](#)

## S

SCPI remote interface error queue  
characteristics, [17](#)

## T

test descriptions, [75](#)

frequency response, [96](#)

test list

functional testing, [75](#)

testing, [75](#)